



NEXUS™ Lane Machine

Service, Operation, and Service Parts Manual

May 2026 / 14-900123-000

Caution: Read this instruction manual before using the NEXUS™ Lane machine.

©May 2026 by Brunswick Bowling Products, LLC. All rights reserved.

NEXUS is a registered trademark of Brunswick Bowling Products, LLC.

If available, updates to this manual can be found on-line at <https://support.brunswickbowling.com/hc/en-us>. Confidential proprietary information. All information contained in this document is subject to change without notice.

Brunswick Bowling Products, LLC.

525 West Laketon Avenue

Muskegon, MI 49441-2601 U.S.A.

Table of Contents

SECTION 1 – SAFETY INFORMATION..... 2

SECTION 2 – INTRODUCTION 4

SECTION 3 – OPERATION..... 12

SECTION 4 – MAINTENANCE AND ADJUSTMENTS 16

SECTION 5 – TROUBLESHOOTING19

SECTION 6 – PARTS DIAGRAMS..... 21



SECTION 7 – ELECTRICAL SCHEMATICS 41

Section 1 – Safety Information

This section provides essential safety information, including the meaning, placement, and purpose of all product safety labels and warnings, along with required precautions for safe operation and maintenance. Review this information carefully to prevent accidents, injuries, or equipment damage before using the product.

1.1 Safety Labels Overview

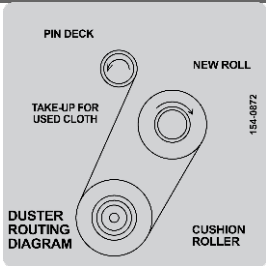
This manual will outline proper operation and maintenance of the NEXUS™ Lane Machine. For clarification, contact a qualified professional or Brunswick Technical Support (BTS) at 1-800-YES-BOWL (1-800-937-2695), via email at techsupport@brunswickbowling.com , or through the Help Center for non-emergency support, documentation, and troubleshooting: <https://support.brunswickbowling.com/hc/en-us>

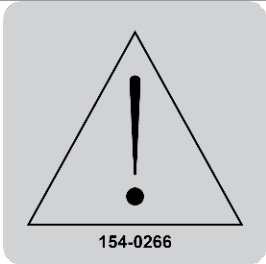
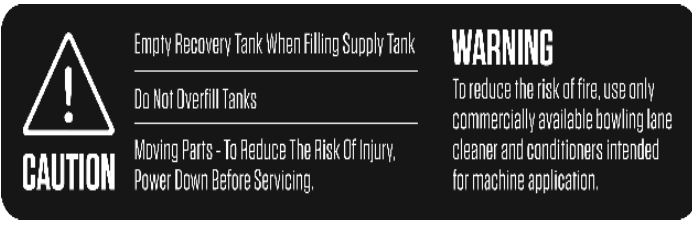
Machine and Safety Labels	
	
<p>Duster Cloth Routing Diagram</p>	<p>No Hands / Hand Crush Warning</p>
	
<p>Caution / General Danger Warning</p>	<p>Tanks Overfilling / Moving Parts Warning</p>

1.2 Important Safety Information

WARNING! Follow these precautions to avoid severe injury or damage to the machine, facility, or other equipment.

- Read this manual before use. Operate only by authorized, trained personnel; prevent unauthorized use by engaging the emergency stop and storing securely.
- Turn off pinspotters before conditioning lanes. Do not run if anyone is on the lane or near the pinspotter. Stay clear of the machine's path, especially at the foul line.
- Use only for cleaning and conditioning bowling lanes. Do not use to collect hazardous dust (e.g., resurfacing or construction debris).
- Use only approved, non-flammable, non-toxic cleaners and conditioners. Avoid spills when filling tanks; do not fill oil tanks on the approach. Follow product labels; flush eyes with water for 15 minutes if contact occurs.
- Turn off the machine if foam or liquid exits the vacuum exhaust.
- The machine is heavy—use team aid when moving and prevent tipping. Secure when not in use. Be aware of slip hazards on wet surfaces.
- Charge only on a properly rated, dedicated, grounded circuit.
- Do not operate with the hood open except for troubleshooting. Use caution when lids are open; components may be hot. Ensure all lids are closed and latched before storage.
- Keep hands, loose clothing, hair, and personal items clear of moving parts (linkages, gears, chains, belts).
- Do not change wiring, components, or safety devices except by qualified technicians; restore all safeguards before operation. Use only Brunswick-approved parts.
- Do not use, clean, or store the machine outdoors or in wet conditions.
- Remain aware of others nearby during operation, especially children.
- Dispose of waste (oil, cleaner, debris) per local, state, and federal regulations. Do not discharge into septic or sewer systems; consult local waste authorities.

1.3 Technical Terms & Abbreviations

Quick reference for terms used in operation and maintenance.

Term	Definition
NEXUS™	Complete lane machine unit
Fatal Error	Stops operation, resets components, returns to idle
Non-Fatal Error	Operation continues; notification displayed
Controller	Main system computer
Control Board	I/O circuit boards
LDS	Lane Distance Sensor
UI	User Interface
IPS	Inches per second
Ft / Cm	Distance units (feet / centimeter)
mL	Volume (milliliter)
V / Amp / Ah	Electrical units (Voltage / Ampere / Amp-Hour)
DC	Direct current
Specs	Specifications
Oil / Conditioner	Lane treatment product (terms used interchangeably)

Section 2 – Introduction

This manual provides essential instructions for the safe, efficient operation, maintenance, and troubleshooting of the NEXUS™ Lane Machine. NEXUS™ is a multifunctional lane maintenance system designed to clean and condition bowling lanes: its cleaning function removes dirt and oil and can be used independently or with conditioning, while its conditioning function applies oil to create a consistent lane pattern.

2.1.1 Cleaning

The cleaning operation sprays solution through front nozzles at a preset rate and pattern to fully cover the lane without gutter overspray. A cloth and cushion roller work the solution into existing oil to form an emulsion, which is then removed by the squeegee and vacuum and collected in a recovery tank. Cleaning occurs only during the forward pass and can be bypassed using the “Oil Only” option.

2.1.2 Conditioning

The conditioning system (Figure 1) applies oil from the tank via a side-to-side oscillating oil head during the forward pass. The optimizer bar then smooths the oil across the lane surface during both forward and reverse passes. Factory default settings apply lighter oil to the outer 7 boards (~7.5 in / 19 cm), slightly more to boards 8–10 (~3.25 in / 8 cm, the “track”), and heavier oil across the middle 20 boards, creating a typical house pattern. Pattern length can be adjusted to meet center needs.

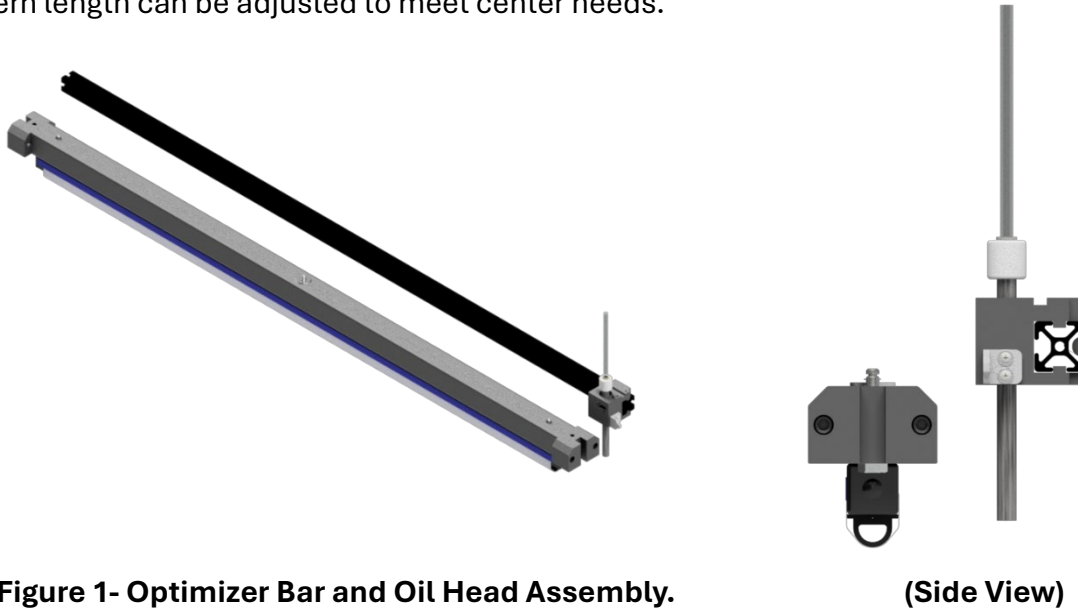

2.1.3 Factory Programming

NEXUS™ performs a single pass per lane with forward and reverse segments. During the forward pass, the lane is cleaned, then oiled and smoothed per the selected pattern. During the reverse pass, the lane is smoothed again; no cleaning or oiling occurs. All patterns allow on-demand modes: Clean & Oil, Clean Only, or Oil Only, and can be adjusted in length. The machine includes five factory patterns: A,B,C, & D for full length lanes (~60 ft) and a SHORT LANE pattern for lanes between 30-50 feet. See Section 3.10 for more details on factory settings and adjustments.

2.2 Uncrating

Before uncrating, inspect the machine for any shipping damage and file claims directly with the freight carrier; Brunswick is not responsible for transit damage. Verify all components are included and undamaged and become familiar with machine components.

IMPORTANT: The cushion roller assembly and optimizer bar are secured with wire ties for shipping protection. Before using the machine, in the standing (transport) position, remove the two wire ties secured at each end of the cushion roller, and each end of the optimizer bar (Figure 2).

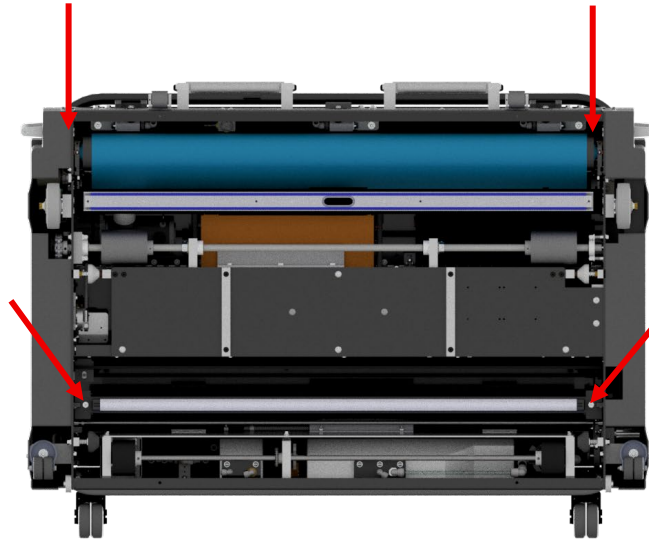

Figure 2 – Wire tie locations

Complete the following steps prior to first operation if NEXUS battery shipped separately:

1. Place the machine in the operating position.
2. Open the cleaner-side compartment and find the battery mounting area.
3. Remove the fasteners and support brackets from the battery posts.
4. Position the battery in place.
5. Reinstall the holding bracket onto the posts to secure the battery.

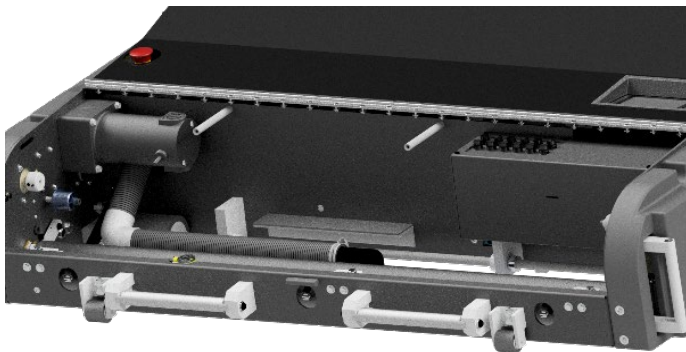

Figure 3 - NEXUS™ before battery installation

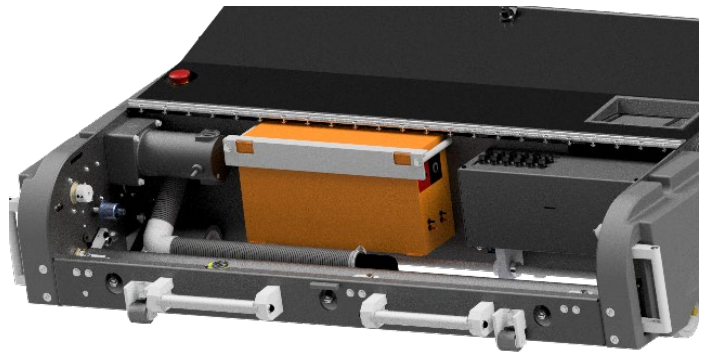

Figure 4 - NEXUS™ after battery installation

2.3 Specifications, Dimensions, and Capacities

The below table summarizes the NEXUS™ Lane Machine’s electrical system, weight, dimensions, and tank capacities.

Property	Specification
Electrical	24V DC battery, 45 Ah nominal
Overcurrent Protection	Individual fuses for motors/controls; battery includes internal protection and temporary disconnects during high current events
Machine Weight	265 lb. (120.2 kg) without battery
Battery Weight	29 lb. (13.1 kg)
Dimensions (H × W × L)	15.5 in (39.37 cm) × 55.25 in (140.34 cm) × 38.75 in (98.43 cm)
Cleaner Tank	1.78 gal (6.73 L), ~16 lanes (on approach start)
Recovery Tank	~1.73 gal (6.54 L), up to 16 lanes
Oil Tank	0.30 gal (1.15 L), up to 24 lanes (less with higher output patterns)

2.4 NEXUS™ Components Overview

The following sections provide an overview of the NEXUS™ Lane Machine’s core components to support understanding of its structure and function. Illustrations intentionally omit lids and panels to show internal and external components clearly and help familiarize users with the machine layout. Components are shown from multiple views (top, bottom, front, 7-pin, and 10-pin), with each image highlighting only the relevant parts for clarity. For detailed information on component functions, operation, maintenance, and parts, refer to the appropriate sections of this manual.

2.4.1 Front View

#	Description
1	Handle
2	Handle Button
3	Back Wheels Casters
4	Front Wheels
5	Cleaner Spray Nozzles
6	Front Lifting Handles
7	Momentary Wheels
8	Transport Handles

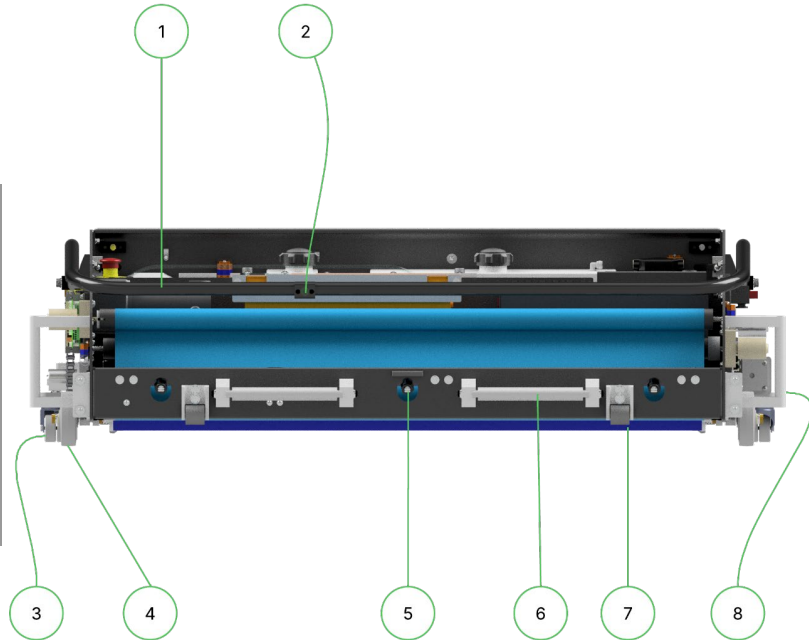

2.4.2 Bottom View

#	Description
1	Front Guide Rollers
2	Drive Wheels
3	Squeegee Cartridge
4	Cushion Roller & Duster Cloth
5	Rear2Guide Rollers
6	LDS Wheels
7	LDS
8	Optimizer Bar

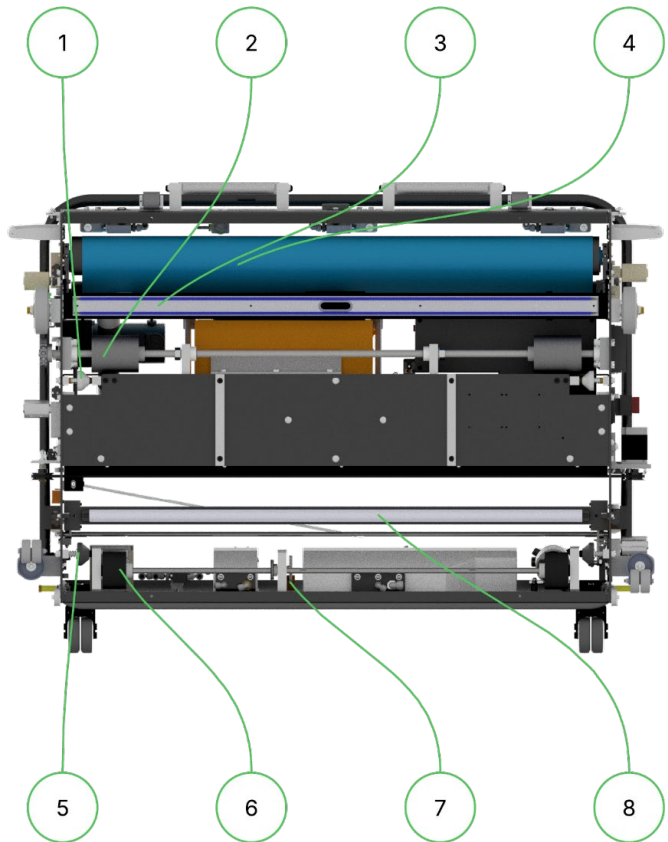

2.4.3 Top View

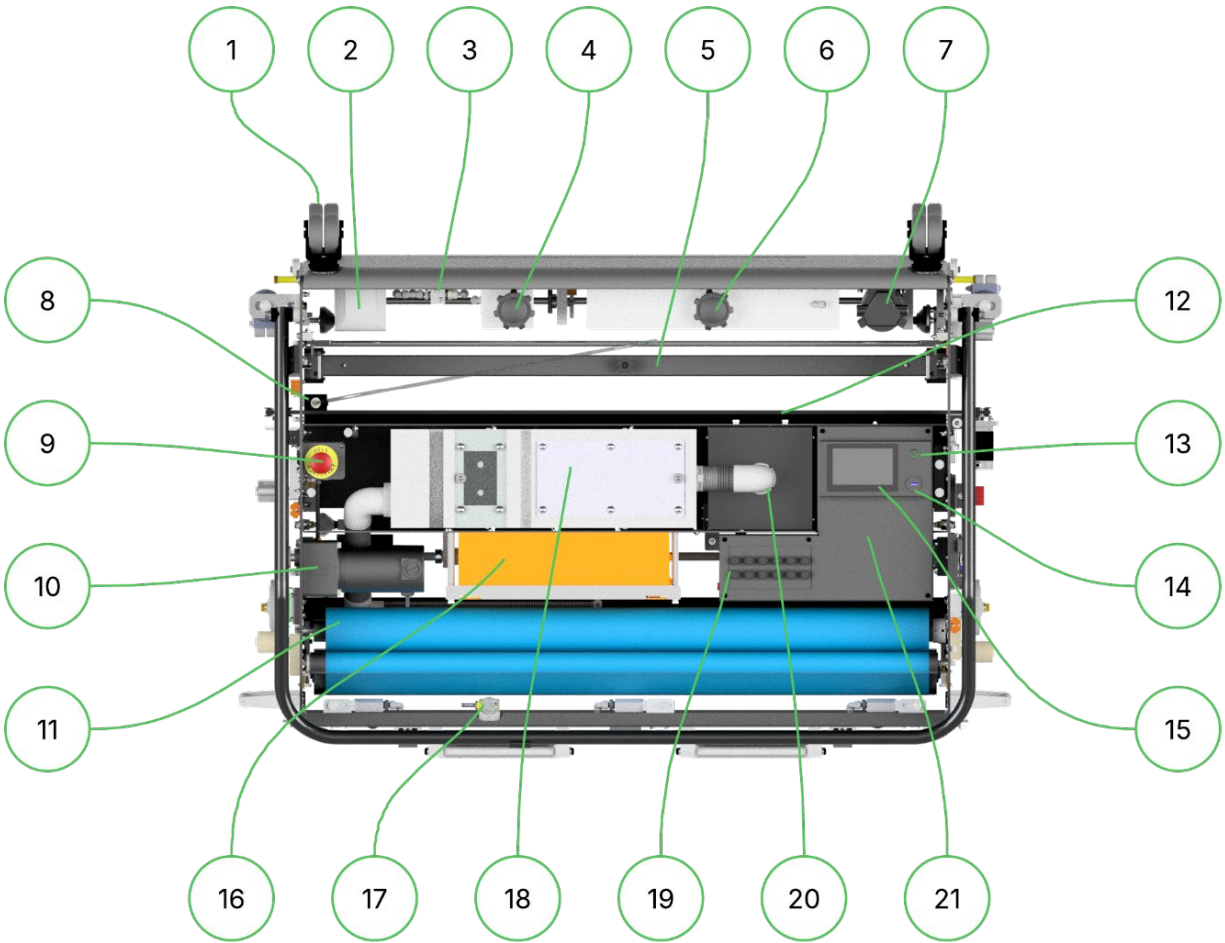

#	Description	#	Description
1	Transport Wheels	12	Oil Head Bar
2	Oil Pump	13	Power Button
3	Three-way Oil Valve	14	USB Port
4	Oil Tank	15	Touchscreen
5	Optimizer Bar	16	Battery
6	Cleaner Tank	17	End of Lane Sensor
7	Cleaner Pump	18	Recovery Tank
8	Oil Head	19	Fuses
9	E-Stop	20	Vacuum Motor
10	Drive Motor	21	Electrical Control Box
11	Duster Cloth		

2.4.4 Seven Pin Side

#	Description
1	Duster Unwind Motor
2	Battery Charging Plug
3	Optimizer Bar Lift Motor
4	Squeegee Adjustment
5	Oil Head Driver
6	Oil Head Motor

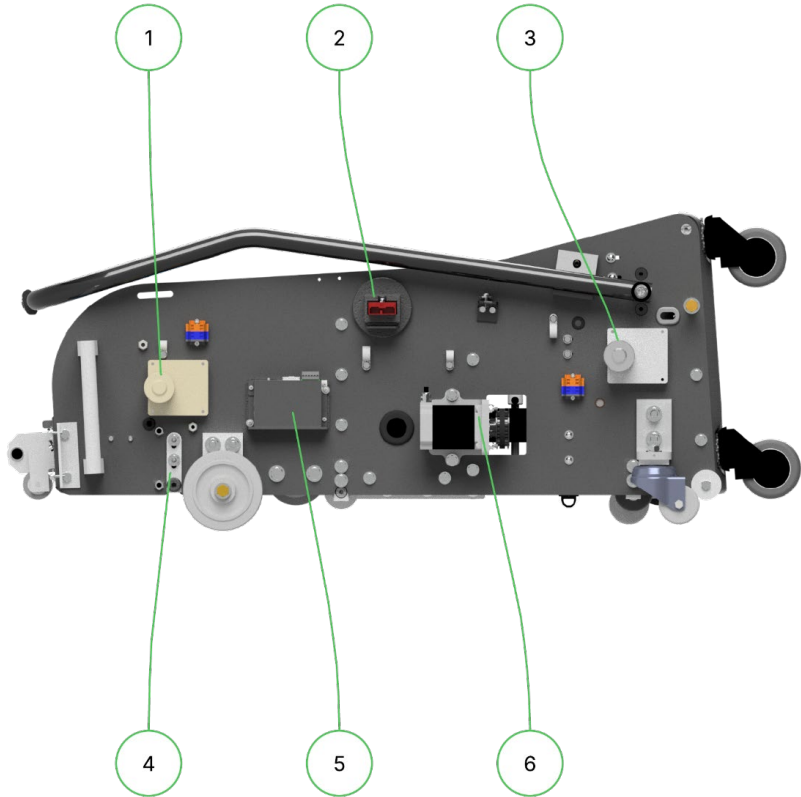

2.4.5 Ten Pin Side

#	Description
1	Squeegee Lift Motor
2	Drive Speed Control
3	Duster Windup Motor
4	Power Distribution Block
5	Oil Head Home Sensor
6	Drive Motor
7	Drive Shaft
8	Squeegee Adjustment

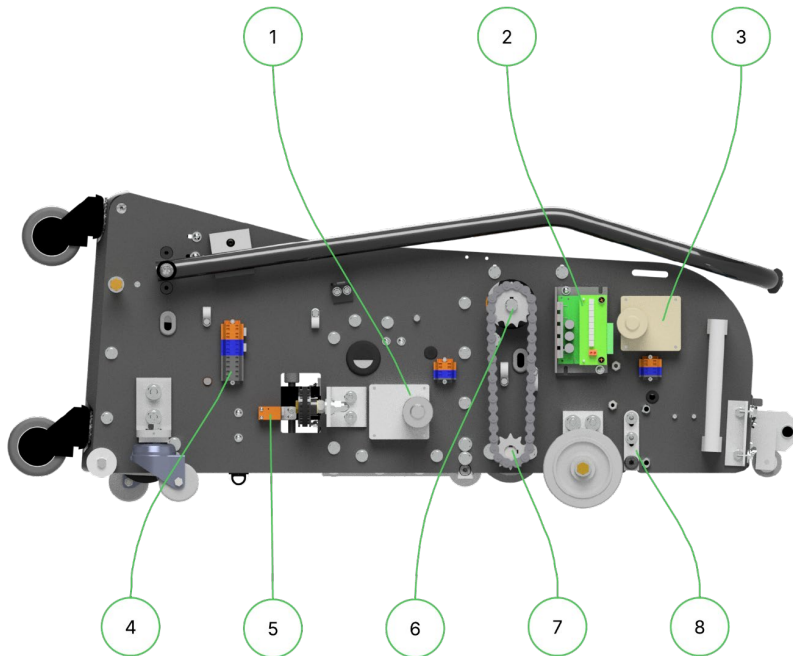

2.4.6 Top Electrical Control Box

#	Description
1	Power Button
2	USB Port
3	Touchscreen
4	Inputs & Analogs Outputs Board
5	Relay Board
6	Fuses
7	Power Port

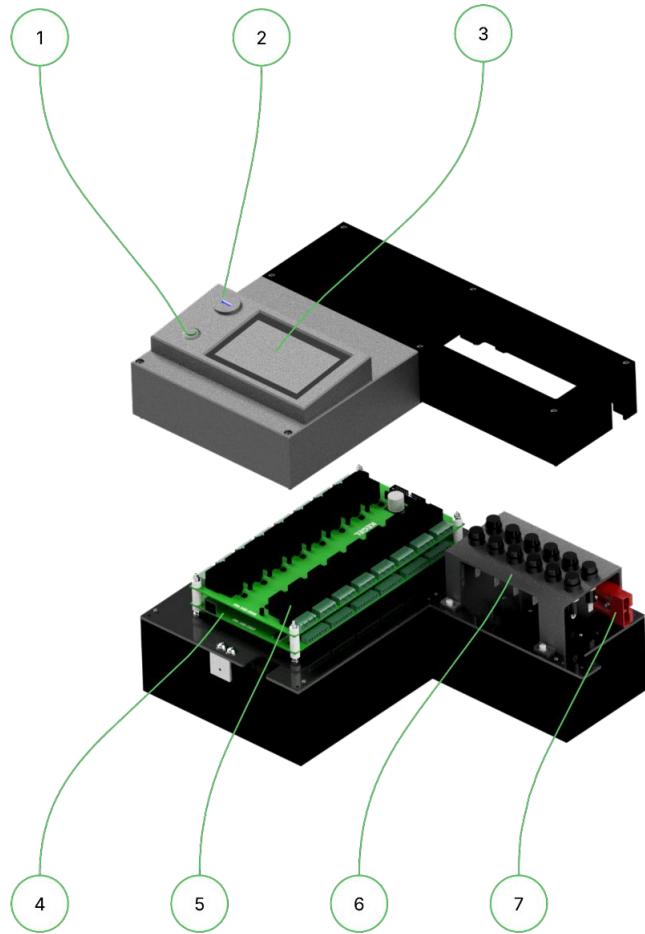

2.4.7 Bottom Electrical Control Box

#	Description
1	Controller
2	24v to 12v Step Down
3	Power Distribution Terminal Block
4	Power Contactor
5	Vacuum Contactor

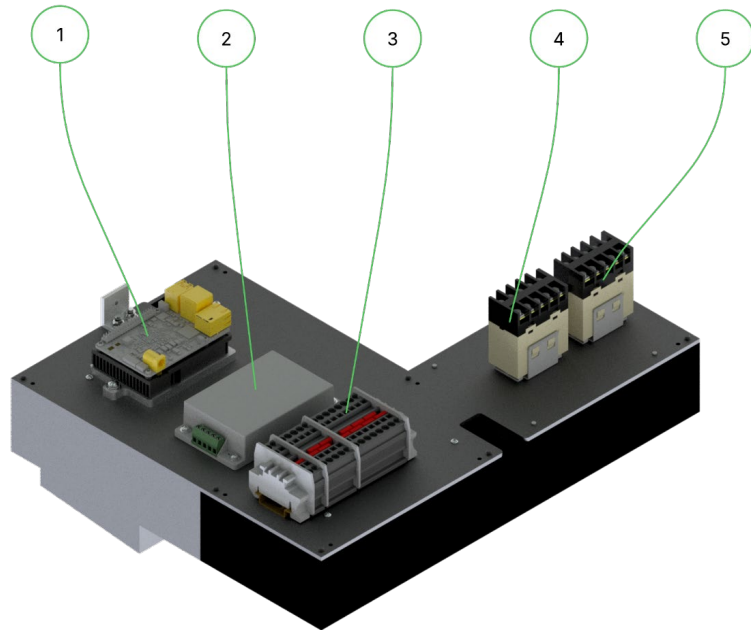

Section 3 – Operation

This section provides step-by-step instructions, safety precautions, and best practices for safe, efficient operation of the NEXUS™ Lane Machine.

Basic Operation Steps:

1. Fill cleaner and oil tanks; empty the recovery tank.
2. Close all lids and covers.
3. Power on the machine.
4. Select operation mode and pattern.
5. Follow on-screen prompts or press Start.
6. Press the handle button once to deploy the duster cloth, lower the squeegee, and activate the oil pump.
7. Place the machine on the lane.
8. Press the handle button again to begin operation.
9. Empty the recovery tank every 16 lanes or less.

3.1 Operation Summary

- The NEXUS™ uses two systems: cleaning and conditioning. During cleaning, solution is pumped from the tank to spray nozzles, applied in controlled intervals (default every 2.5 ft for .2 seconds up to a set distance), mixed with lane oil, agitated by the duster cloth, and removed by the squeegee and vacuum into the recovery tank. Cleaning occurs only during forward travel when selected. Cleaning and conditioning may be performed independently or together, with cleaning limited to the forward pass. During conditioning, an oscillating oil head applies conditioner based on programmed patterns, regulated by a software-controlled valve. The optimizer bar smooths the oil into a uniform film, then lifts once application is complete.
- The machine is driven by a DC motor and guided by rollers, a front optical sensor (detects end of lane), and the Lane Distance Sensor (LDS), which tracks position and controls when operations start and stop. The machine travels forward to clean and/or oil, then reverses back to the foul line. In Oil-Only mode, it reverses at the end of the programmed pattern distance.
- The battery will require charging after prolonged use. After 15 minutes of no use, NEXUS will enter a sleep mode to preserve battery capacity. When charging is required, use the provided wall charger – ensuring the outlet is on a properly rated, dedicated, grounded circuit.

3.2 NEXUS™ Lane Machine Controls

The NEXUS™ is controlled via a touchscreen interface and a single handle-mounted push button. The touchscreen (Figure 3) allows users to navigate settings and control functions, while the handle button provides direct input for key actions. Power is controlled by the emergency stop (E-Stop – Figure 4) and the touchscreen power button. Engaging the E-Stop immediately cuts power and halts operation. To power on, disengage the E-Stop (rotate clockwise) and press the power button near touchscreen.

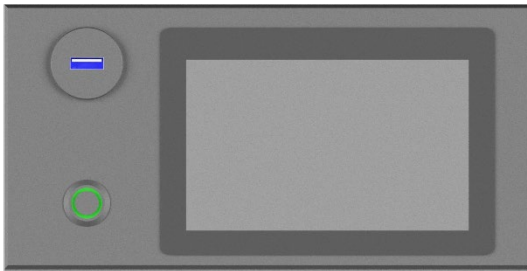

Figure 3 – Touchscreen, Power ON Button, and USB Port



Figure 43 - Emergency Stop (E-Stop)

3.2.1 Touchscreen Overview

Home Screen: (Figure 5)

Primary access point for operation and settings. The green crown button reveals cleaning and conditioning options; the settings button opens machine settings and diagnostic tests. It also displays software version (date-based format) and battery status (green >24V, red <24V with warning).

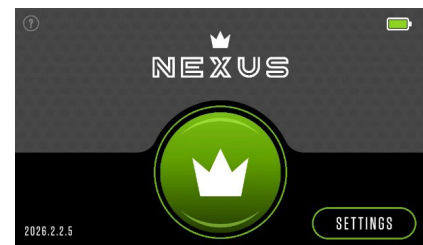

Figure 5 - Home Screen

Conditioning Screen: (Figure 6)

Allows selection of patterns A–D (fixed names), each with adjustable oil distance (within defined ranges) and start distance (20–30 in). Displays pattern details and supports three modes: Clean & Oil, Clean Only, or Oil Only. Press Start to begin operation.



Figure 6 - Conditioning Screen

Short Lane Mode: (Figure 7)

Enabled in settings for lanes under 50 ft. Uses a fixed pattern (14–20 ft oil distance, adjustable; start distance 20–30 in) with the same three operating modes.



Figure 7 - Short Lane Mode Screen

Running Screen: (Figure 8)

Displays active pattern, distance from foul line, target/actual speed (IPS), lane count, oil distance, start distance, and selected mode. A STOP button halts operation, resets the machine, and returns to the home screen.

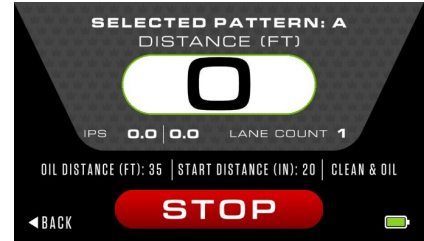

Figure 8 - Running Screen

3.2.1.5 Machine Settings Screen: (Figure 9)

Allows operators to adjust NEXUS™ operation, reset the duster cloth, and restore factory defaults.

Key Settings:

- **Machine Start Guide:** Enables on-screen prompts during operation (default: enabled).
- **Present Unwind Time:** Duster unwind duration (ms), auto-increases 2 ms per lane to compensate for roll diameter changes as cloth is consumed.
- **# of Lanes on Roll:** Remaining duster cloth capacity; decreases per lane. Warning appears below 16; error at 0.
- **Short Lane Mode:** Enables fixed short-lane pattern and bypasses standard pattern selection (recommended <50 ft).
- **Cleaning Distance:** Sets cleaner application distance only (default: 50 ft).

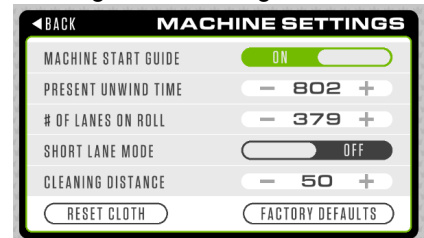

Figure 9 - Machine Settings Screen

Functions:

- **Reset Cloth:** Resets *Present Unwind Time* (800 ms) and *# of Lanes on Roll* (380) after replacing duster cloth.
- **Factory Defaults:** Restores all settings to default except *Present Unwind Time* and *# of Lanes on Roll*.

3.2.1.6 Machine Info Screen: (Figure 10)

Displays read-only system data including software version, QC date, and total lanes serviced.

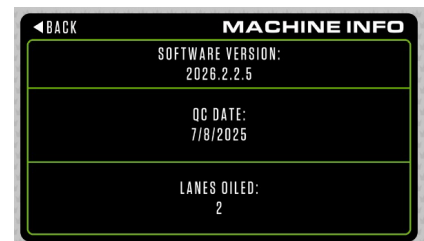

Figure 10 - Machine Info Screen

3.2.1.7 Drive Calibration Screen: (Figure 11)

Adjusts drive motor behavior, including:

- **Drive Speeds:** Range (2000-2450): Motor speed (mV ranges; higher = faster). (Range = 2900 – 3300)/
- **Backend Speed:** Speed from pattern end to 50 ft. (Range = 1000 – 5000).
- **Pin Deck Speed:** Speed at 50 ft. (Range = 2000 – 2500)
- **Return Rang Speed:** Range (1000-5000)

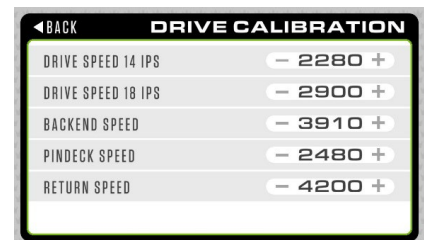

Figure 11 - Drive Calibration Screen

3.2.1.8 Input Tests Screen: (Figure 12)

Read-only display of all inputs; indicators illuminate green when active and black when inactive. Used for verification and troubleshooting.

3.2.1.9 Output Tests Screen: (Figure 13)

Allows manual activation of machine components; button presses toggle outputs (green = active). Use caution, as components may move or dispense fluids when activated.

3.2.2 Handle Button:

- Press handle button once (on approach) to lower duster, squeegee, and optimizer bar.
- Push machine onto the lane, ensuring it's centered.
- Press handle button again to begin operation.
- When idle, the handle button will operate the drive motor in reverse.

3.2.3 E-Stop & Power:

The E-Stop immediately cuts power when engaged. To power ON the machine, disengage (rotate clockwise), then press the power button and wait for system initialization.

3.3 Positioning

Move the machine to the approach while in the transport position. Orient the bottom of the machine towards the foul line and carefully lower the machine into the operation position.

3.4 Handle

Used to move the machine between lanes and start operation. When the machine travels down the lane, lower the handle gently to ensure clearance with the pinspotter.

3.5 End of Lane

The NEXUS™ uses an end-of-lane sensor to detect lane surface presence. When running lanes, it recognizes the lane at the foul line, triggering a pulse of cleaner to spray. When the machine reaches the pin deck and the lane's surface is no longer detected (end of lane/pin deck), the machine automatically reverses and returns to the foul line.

3.6 Preparing for Use

Proper setup includes safely filling the cleaner and oil tanks to prevent spills or damage.

Adding Cleaner:

Place the machine in operating position, remove the cleaner tank cap, insert a funnel (with towel at base), and fill with pre-mixed cleaner to ~1 in (25.4 mm) below the top.

Adding Oil:

Repeat the same process for the oil tank, filling to ~1 in (25.4 mm) below the top.

3.7 Cleaning the Lane Head Area

In Clean Only or Clean & Oil modes, a small line of cleaner residue may appear near the foul line from the Squeegee Blades. Wipe it off with a clean towel for best results.

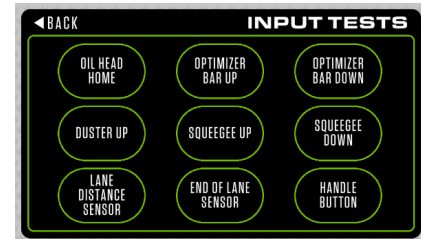

Figure 12 - Input Tests Screen

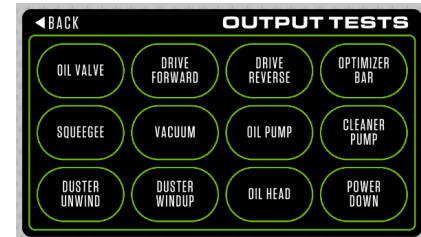

Figure 13 - Output Tests Screen

Section 4 – Maintenance and Adjustments

Routine maintenance ensures the NEXUS™ Lane Machine proper operation and consistent lane conditioning. This section covers periodic maintenance, performance adjustment/testing, and replacement of worn parts. Always turn off power before servicing.

4.1 After-Use Maintenance

Clean the machine after each conditioning session to prepare for the next session. Tasks may be done in any order (recommended sequence below). **Prevent oil from entering cleaning components and cleaning solution from entering oiling components.**

4.1.1 Operating Position Tasks:

Oiling Area

- Check and refill conditioner and cleaner levels as needed.
- Secure both caps.

Cleaning Area

- Ensure sufficient duster cloth is available on the supply roll.

Recovery Tank

- Remove, empty (per local environmental regulations*), rinse, and reinstall.
***Do not dump recovery tank in a septic tank or sanitary sewer system.**

Frame & Exterior

- Wipe frame and transport casters.

4.1.2 Upright Storage Position Tasks:

Cleaning Area

- Clean squeegee blades with clean towel; inspect for damage.
- Inspect cushion roller assembly for damage.

Oiling Area

- Wipe optimizer bar (clean, dry cloth).
- Clean LDS wheels, drive wheels, and all four guide wheels.

Exterior Components

- Wipe all external surfaces, including casters, wheels, top, sides, base plate, and both cleaning and oiling areas.

4.2 Weekly Maintenance

In addition to after-use maintenance, perform these weekly tasks:

- Evaluate machine performance.
- Clean the exterior of the cleaner tank, oil tank, and surrounding areas.
- Clean the exterior of the recovery tank, optimizer bar, and surrounding areas.
- Blow out the machine thoroughly with an air compressor.

4.2.1 Performance Testing

Verify cleaning and conditioning functions to ensure proper setup and operation.

Cleaning Function Check

- Run Clean Only on 2–3 lanes and inspect results.

4.2.2 Cleaning the Optimizer Bar

- Clean after each use with a dry cloth, wiping side to side.

Do not use cleaning solutions.

4.3 Occasional Maintenance

4.3.1 Adjusting the Squeegee Assembly

Proper adjustment ensures effective cleaning over lane surface irregularities:

- Too high → cleaner puddles will appear on lane surface.
- Too low → haze and streaks will be left on lane surface.

Adjustment Steps - Height

1. Remove 7- and 10-pin side guards; raise machine into transport position.
2. Lower squeegee from SETTINGS -> OUTPUT TESTS menu; place a straight edge from blades to lane distance wheels.
 - Gap to drive wheels: **1/8"-3/16" (3.18–4.76 mm)** on both sides.
3. If incorrect, loosen pivot bolts (two per side).
4. Adjust pivot height evenly on both sides, then tighten bolts.

Adjustment Steps – Pitch

1. Locate the squeegee motor on the right side. The cam, rod end, and rod control the squeegee movement.
2. Loosen the jam nut on the rod and remove bolt from rod to cam.
3. Rotate the rod end to adjust pitch (do not shorten the linkage too much) and reinstall.
4. Check the gap between the straight edge and drive wheels and tighten nut.

4.3.2 Adjusting Cleaner Spray Nozzles

The machine uses three stainless steel jets that spray cleaner in a “V” pattern across the lane. Though factory-set, adjustments may be needed to ensure full coverage without channel overspray.

- **Too narrow (edges not covered):** raise spray tips slightly or rotate jets outward.
- **Too wide (overspray):** angle tips downward or toward center.

Adjustment Steps

1. Loosen the hex bolt on the spray jet assembly and rotate the jet as needed.
2. Adjust the middle jet ($\approx 45^\circ$ or 135°) for best coverage pattern, then tighten.
3. Angle outer jets slightly inward to prevent channel overspray; tips should be mostly vertical. **Do NOT overtighten retaining nuts. Hand tight only.**

4.3.3 Adjusting the Optimizer Bar Assembly

Proper adjustment ensures uniform oil coverage over lane surface imperfections and maintains proper traction of the lane machine during operation:

- Too high -> oil puddles appear on lane surface.
- Too low -> traction issues while traveling on the lane.

Adjustment Steps

1. Raise machine into transport position.
2. Locate the two adjustment bolts on the bottom of the Optimizer Bar Assembly.
 - If the jam nuts are not bottomed out on the head of the bolt, loosen them.
 - To raise the assembly, back the bolts out evenly in ¼ to ½ turn increments.
 - To lower the assembly, turn the bolts inward evenly in ¼ to ½ turn increments.
 - Once Adjusted, tighten the jam nuts against the Optimizer Bar Assembly.
3. Run the machine and verify proper traction and uniform oil smoothing across the lane surface.

4.3.4 Fuse Replacement

The NEXUS™ Lane Machine uses **12 fuses** (found on top of the control box) to protect electrical components. Push down and turn counterclockwise on fuse cover and pull straight out to remove or replace fuse.

Fuse Ratings:

Vacuum Motor 20.0A	Squeegee Motor 3.2A	Optimizer Lift Motor 3.2A	Duster Windup 0.5A
Oil Pump 0.75A	Cleaner Pump 3.2A	12V Power Supply 4.0A	Duster Unwind 0.5A
Drive Board 7.5A	Control Board 1.0A	Oil Head Motor 3.2A	Controller 2.25A

4.4 Replacing Parts

4.4.1 Duster Cloth Replacement

The machine uses a ratcheting cloth system with two brake motors: one feeds cloth and lowers the cushion roller; the other winds the used cloth and lifts the roller, preventing dirt lines and manages cloth control.

Replacement Steps

1. Remove and discard used cloth. Clean the compartment while accessible.
2. Transfer pipe to new core, unroll ~3 ft, and install new roll. Route cloth per diagram (10-pin wall), between squeegee and cushion roller, then under the roller.
3. Pull excess cloth through and wrap 3–4 turns evenly on the take-up reel. Install the take-up reel.

4. Use the duster motor control to unwind/rewind until cloth is tight and even. Reset cloth usage in Settings by selecting “Reset Cloth.”

4.4.2 Squeegee Blade Replacement

The squeegee assembly is critical for cleaning performance. Inspect after each use.

- At 4,500 lanes, rotate cartridge 180° to use the fresh edge. Replace both after 9,000 lanes. Replace immediately if blades are torn, brittle, or warped.

Steps (machine in transport position):

1. Remove four hex bolts; take out cartridge.
2. Remove four Allen bolts from squeegee channel.
3. Remove channel insert, discard blades, and clean/dry all parts.
4. Install new blades evenly, ribbed sides out. Reinstall insert and secure with Allen bolts from Step 2. Install new gasket and remount assembly.

4.4.3 Cushion Roller Replacement (Remove duster cloth first for access.)

1. Remove side guards. In transport position, remove hardware from one pivot arm on either side of the machine. Remove only one side and keep 5/16" spacer washer for future use.
2. Pull roller out carefully from the underside of the machine, avoiding microswitches. Transfer the removed arm to the new roller; shim new roller until stems are flush with bearings. Reinstall with spacer washer and hardware.

Section 5 – Troubleshooting

This section outlines common NEXUS™ Lane Machine problems, solutions, and steps to follow if the machine stops mid-operation. If machine errors are unresolved or not listed, contact Brunswick Technical Support (1-800-YES-BOWL / 1-800-937-2695, techsupport@brunswickbowling.com). **Note:** Repairs should only be performed by experienced operators. Do not attempt procedures that are not fully understood.

5.1 Operational Problems and Solutions

Problems are grouped into six categories:

- **General operation (no error code):** Non-specific issues.
- **General operation (with error code):** Non-specific issues with codes.
- **Cleaning operation (no error code):** Cleaning-related issues.
- **Cleaning operation (with error code):** Cleaning issues with codes.
- **Conditioning operation (no error code):** Conditioning-related issues.
- **Conditioning operation (with error code):** Conditioning issues with codes.

5.1.1 General Operation (No Error Code)

Machine won't turn on:

- Low battery, poor connection, or E-Stop engaged.

5.1.2 General Operation (With Error Code)

- **Forward travel:** Faulty/loose relay, bad drive fuse, loose wiring/fuse holder, bad LDS sensor, or shaft issue
- **Reverse travel:** Same as forward travel causes.
- **Machine stuck at end:** Drive wheels past tail plank.
- **Short lane:** Ran short-lane mode on standard lane.
- **End-of-lane sensor:** Dirty or defective sensor.
- **Control board connection:** Faulty board, Ethernet connection, or cable.
- **Low battery:** Not charged or poor connection.

5.1.3 Cleaning Operation (No Error Code)

- **Pump runs, no cleaner:** Empty tank or clogged filter.
- **Pump won't run:** Blown fuse or bad relay.
- **Low pump output:** Clogged tank filter.
- **Cleaner left on lane:** Squeegee too high, lane depressions, damaged blades, or missing recovery tank.
- **Oil streaks:** Duster not contacting lane or insufficient cloth feed/reset issue. No Cleaner.
- **Cleans only where sprayed:** Duster not contacting lane.
- **Drips from squeegee:** Rear squeegee misaligned, clogged recovery filter/hose, or weak vacuum motor.
- **Cleaner pushed into gutters:** Missing tank, disconnected hose, or excess cleaner.
- **Cleaner leak:** Tank fitting leak or overflow.
- **Uneven duster cloth:** Improper winding, misadjusted switches, or faulty motor brake.

5.1.4 Cleaning Operation (With Error Code)

- **Duster unwind:** Empty cloth, bad/stuck up switch, bad fuse, duster unwind motor faulty, duster unwind relay faulty. Duster not contacting the lane surface.
- **Duster wind-up:** Bad fuse, faulty motor/relay, bad/stuck up switch, slipping hub.
- **Squeegee up/down:** Bad fuse, faulty relay, motor or loose cam.
- **Low duster cloth:** <16 lanes of cloth left on supply roll.

5.1.5 Conditioning System (No Error Code)

- **Oil pump runs, no pressure:** Clogged filter or empty tank.
- **Oil pump won't run:** Bad fuse or motor.
- **Conditioner leak:** Tank fitting leak or overflow.

5.1.6 Conditioning System (With Error Code)

Oil head drive: Bad fuse, faulty home proximity sensor, or low battery.

- **Optimizer up/down:** Bad/stuck switch, bad fuse, faulty motor, defective lift relay or loose cam.

Section 6 – Parts Diagrams

6.1 E-Stop Assembly

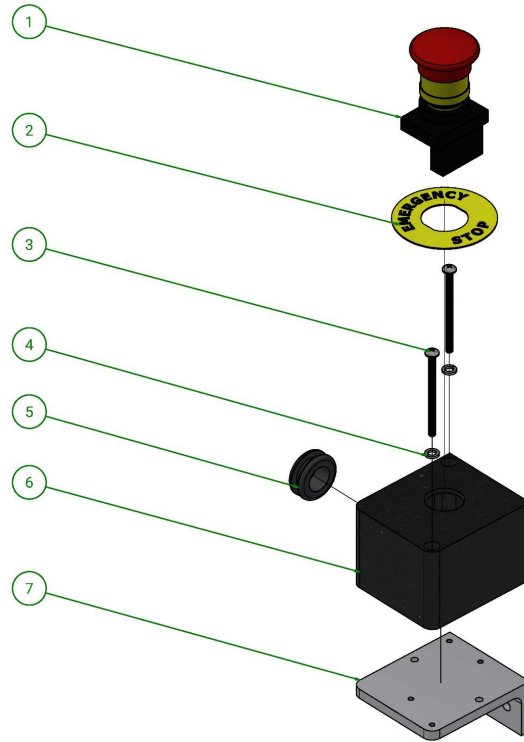

E-STOP ASSEMBLY				
Index Number	Qty.	Part Number	Description	UOM
1	1	164-1223	E-Stop Switch Box	EA.
2	1	155-1234	E-Stop Label	EA.
3	2	153-2557	MS Phillips – 8-32 x 2-1/4"	EA.
4	2	153-2013	Lock Washer - #10	EA.
5	1	153-2934	Grommet	EA.
6	1	166-6062	E-Stop Enclosure	EA.
7	1	154-6273	E-Stop Mount Bracket	EA.

6.2 7-Pin Duster Motor Assembly

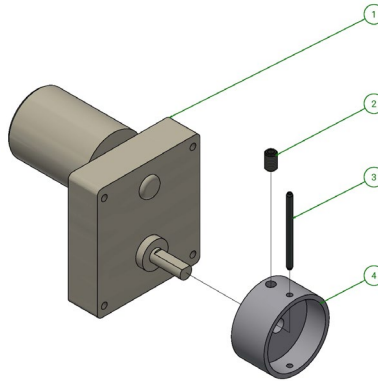

7-PIN DUSTER ASSEMBLY				
Index Number	Qty.	Part Number	Description	UOM
1	1	166-8011	Duster Motor Assembly	EA.
2	1	153-2050	Set Screw – 1/4-28 x 3/8"	EA.
3	1	153-2037	Roll Pin – 1/8 x 1-3/4"	EA.
4	1	153-6225B	Duster Cloth Hub	EA.

6.3 10-Pin Duster Assembly

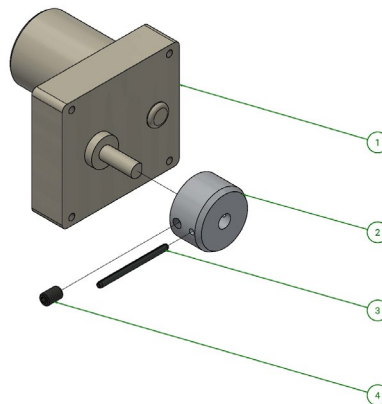

10-PIN DUSTER ASSEMBLY				
Index Number	Qty.	Part Number	Description	UOM
1	1	166-8011	Duster Motor Assembly	EA.
2	1	153-6263B	Duster Cloth Hub	EA.
3	1	153-2037	Roll Pin – 1/8 x 1-3/4"	EA.
4	1	153-2050	Set Screw – 1/4-28 x 3/8"	EA.

6.4 Spray Jet Assemblies

7-Pin Side/Center

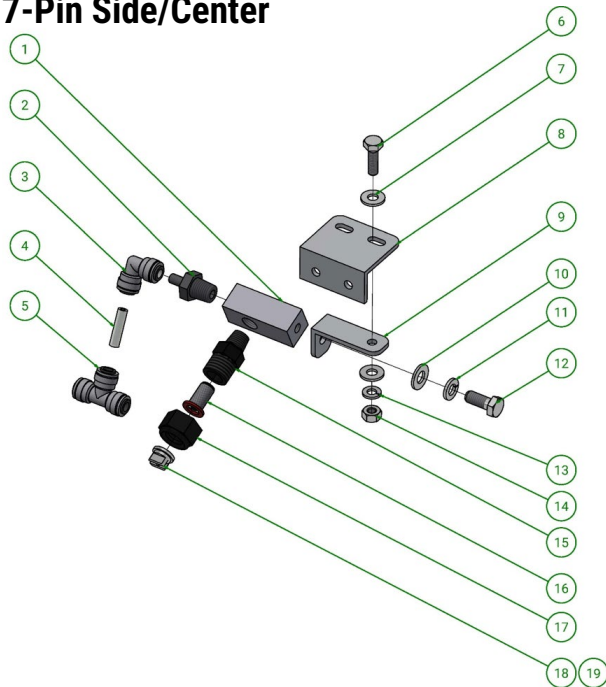

10-Pin Side

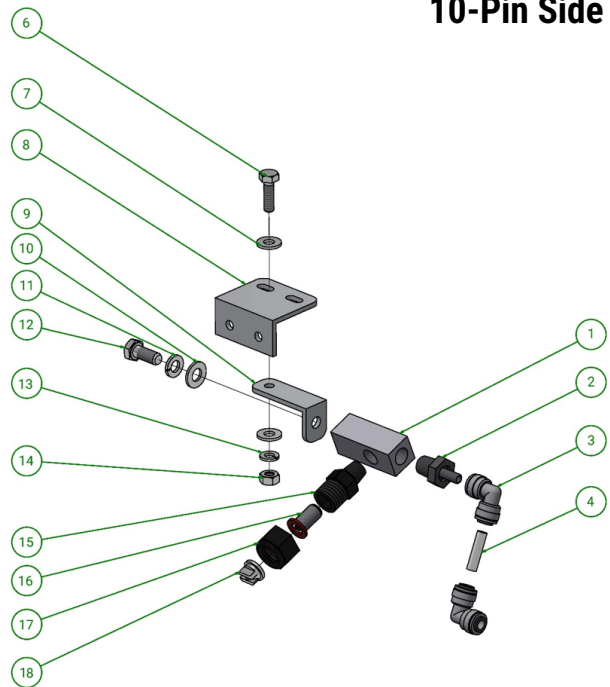

SPRAY JET ASSEMBLIES

Index Number	Qty.	Part Number	Description	UOM
1	1	153-6252	Spray Jet Body	EA.
2	1	154-0243S	Stem Adapter – ¼" x ¼"	EA.
3	1	154-0243	Elbow (90 Degree) ¼" x ¼"	EA.
4	1	153-0208S	Tubing – ¼"	1.75
5	1	153-0815	Union Tee – ¼" ¼" x ¼"	EA.
6	1	153-2052	HHCS – ¼-20 x 7/8"	EA.
7	2	153-2004	Flat washer – ¼"	EA.
8	1	158-6231	Spray Jet Mount Angle	EA.
9	1	153-6251S	Spray Jet Swivel Mounting Angle	EA.
10	1	153-2005	Flat washer – 5/16"	EA.
11	1	153-2015	Lock washer – 5/16"	EA.
12	1	153-2602	HHCS – 5/16-18 x ¾"	EA.
13	1	153-2014	Lock washer – ¼"	EA.
14	1	153-2023	Hex nut – ¼-20	EA.
15	1	153-0217	Male Body – ¼"	EA.
16	1	153-0220	Screen Check Valve	EA.
17	1	153-0218	Tip Retainer Cap	EA.
18	1	154-0007	Spray Tip Assembly – 1501 (L&R)	EA.
19	1	153-0207A	Spray Tip Assembly – 11003 (Center only)	EA.

6.5 Cleaner Tank Assembly

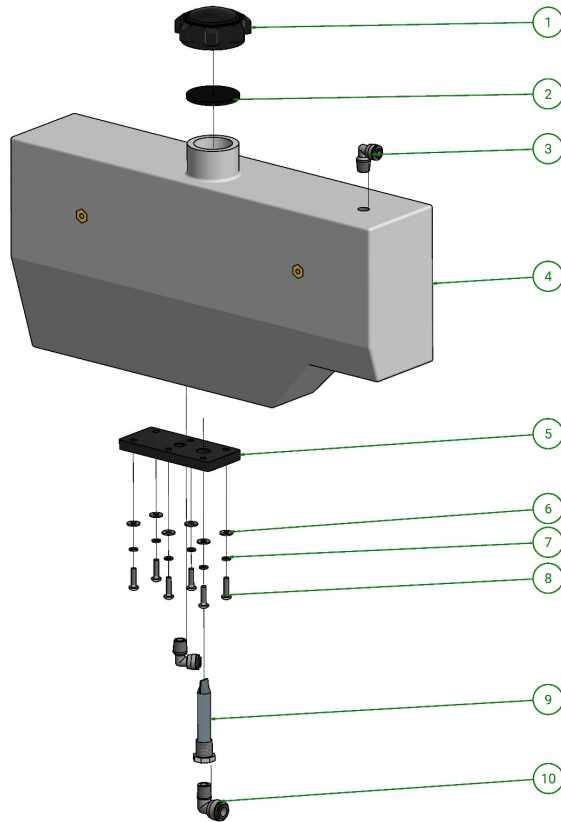

CLEANER TANK ASSEMBLY				
Item Number	Qty.	Part Number	Description	UOM
1	1	164-6018	Kelch Cap	EA.
2	1	164-0021	Kelch Cap Gasket	EA.
3	2	154-0223	Elbow (90 Degree) - ¼ NPT x ¼ Tube	EA.
4	1	165-6091M	Water Tank	EA.
5	1	166-6039	Cleaner Tank Plate	EA.
6	6	153-2003	Flat washer - #10	EA.
7	6	153-2013	Lock washer - #10	EA.
8	6	153-2091	MS Phillips - 10-32 X 3/4	EA.
9	1	154-0212B	Filter – Cleaner Supply Tank (3 IN SS)	EA.
10	1	154-0225	Elbow - 3/8 Tube OD x ¼ NPT	EA.

6.6 Squeegee Assembly

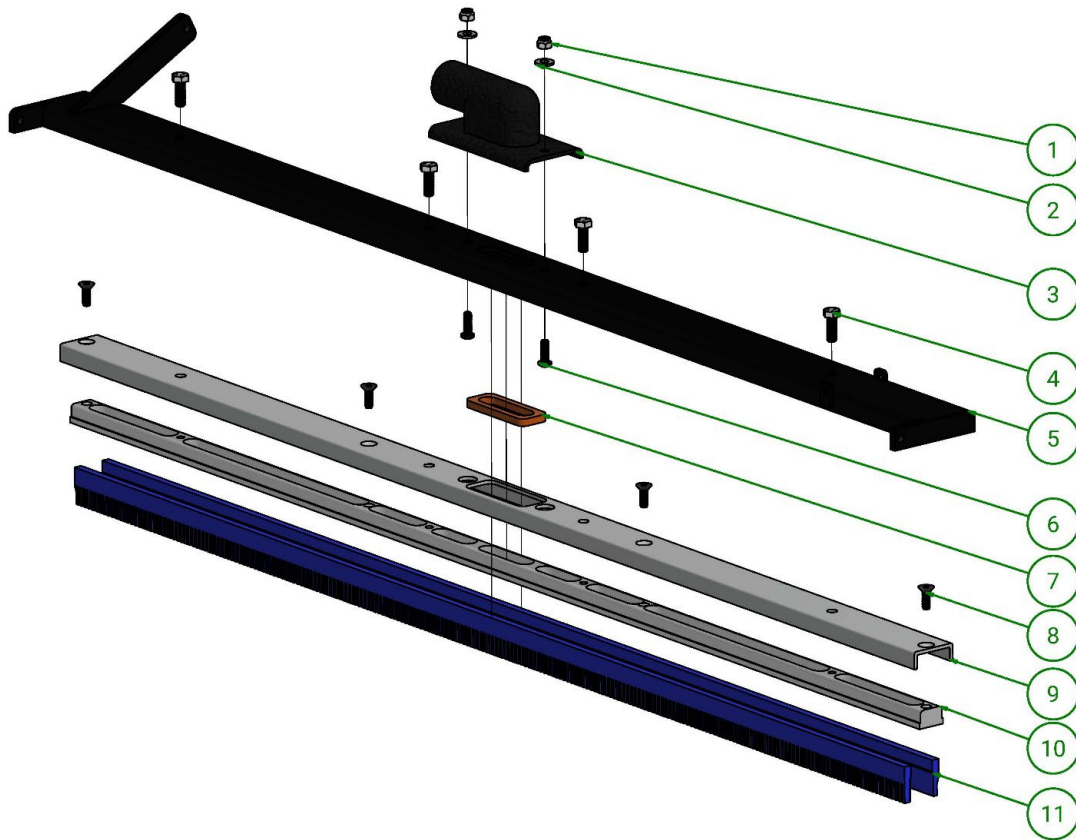

SQUEEGEE ASSEMBLY

Index Number	Qty.	Part Number	Description	UOM
1	2	153-2020A	Locknut – ¼-20 (Stover)	EA.
2	2	153-2004	Flat washer – ¼"	EA.
3	1	154-6677A	Squeegee Hose Adapter	EA.
4	4	164-2097	HHCS – 5/16-18 x 7/8"	EA.
5	1	154-6339-2850	Squeegee Mount Angle - Black	EA.
6	4	153-2968	FHSCS – ¼-20 x ¾"	EA.
7	2	164-2023	BHCS – ¼-20 x ¾"	EA.
8	1	164-0003	Squeegee Gasket	EA.
9	1	164-6074	Squeegee Channel	EA.
10	1	164-6075	Machined Squeegee Channel	EA.
11	1	164-8038K	Squeegee Replacement Blades	KIT

6.7 Vacuum Motor Assembly

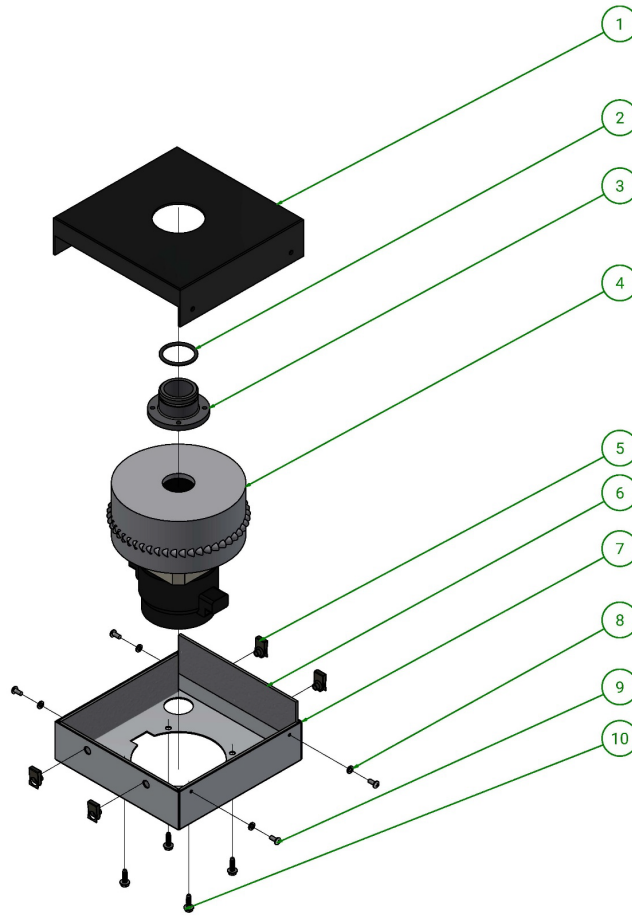

VACUUM MOTOR ASSEMBLY				
Index Number	Qty.	Part Number	Description	UOM
1	1	166-6011-2850	Vacuum Motor Top Plate	EA.
2	1	165-2013	O-Ring - 1-3/8 ID X 1/8 Dia.	EA.
3	1	166-6023	Vacuum Motor Inlet	EA.
4	1	158-1421	Vacuum Motor Assembly - 24v	EA.
5	4	153-2907	Spring Nut - 1/4-20	EA.
6	4	154-0628S	Felt - Gray - 9" x 3/8"	EA.
7	1	158-6211	Vacuum Motor Housing	EA.
8	4	153-2013	Lock Washer - #10	EA.
9	4	153-2113	MS Phillips - 8-32 x 3/8"	EA.
10	4	153-2830	Hex Head Self Tap Screw - #10 x 5/8"	EA.

6.8 Vacuum Hose to Tank Assembly

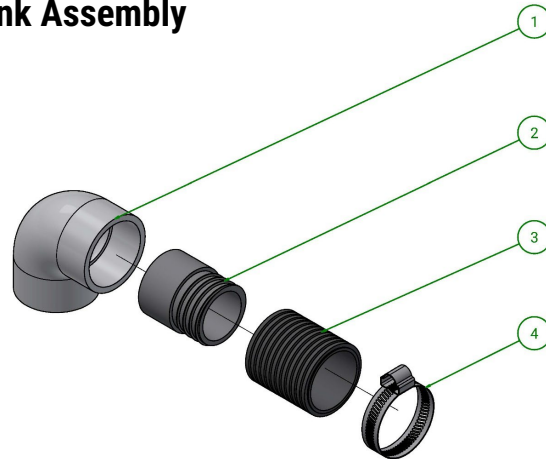

VACUUM HOSE TO TANK ASSEMBLY

Index Number	Qty.	Part Number	Description	UOM
1	1	164-0220	PVC 90 Degree Elbow	EA,
2	1	164-6293	Threaded Insert - 1"	EA.
3	1	154-0260	Flexible Vacuum Hose Grey - 1-1/2"	IN.
4	1	153-2406	Hose Clamp - 2"	EA.

6.9 Squeegee Cam Plate Assembly

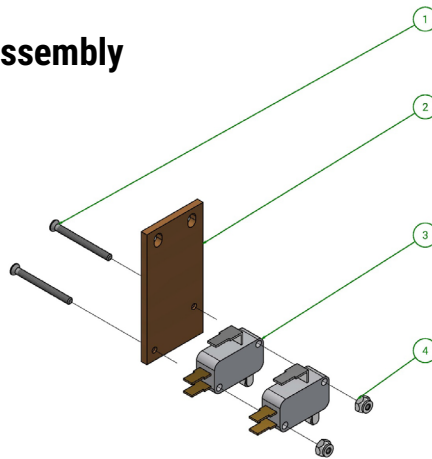

SQUEEGEE CAM SWITCH ASSEMBLY

Index Number	Qty.	Part Number	Description	UOM
1	2	153-2727	FHMS - 4-40 x 1-1/4"	EA.
2	1	154-6824	Cam Switch Plate	EA.
3	2	153-1203	Microswitch w/roller	EA.
4	1	153-2231	Locknut - 4-40	EA.

6.10 Squeegee Hose to Tank

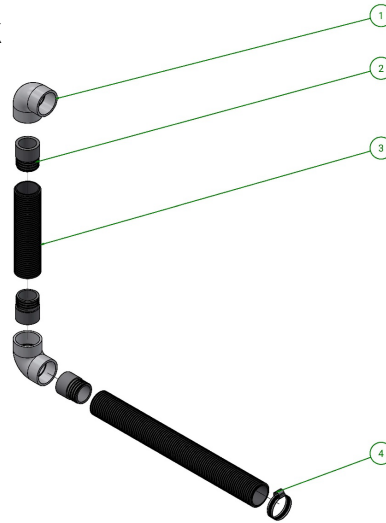

SQUEEGEE HOSE TO TANK ASSEMBLY				
Index Number	Qty.	Part Number	Description	UOM
1	2	164-0220	PVC 90 Degree Elbow	EA.
2	3	164-6293	Threaded Insert - 1"	EA.
3	1	154-0260	Flexible Vacuum Hose Grey - 1-1/2"	IN.
4	1	153-2406	Hose Clamp - 2"	EA.

6.11 Momentary Wheel Assembly

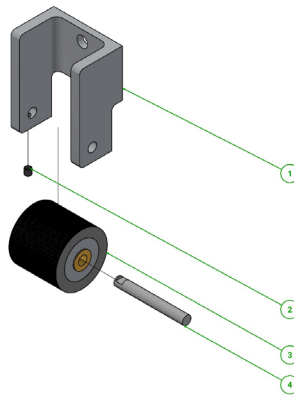

MOMENTARY WHEEL ASSEMBLY				
Index Number	Qty.	Part Number	Description	UOM
1	1	164-6053	Momentary Wheel housing	EA.
2	1	153-2049	Set Screw – 8-32 x 3/16"	EA.
3	1	153-7005	Momentary Wheel	EA.
4	1	153-6006	Lane Roller Shaft	EA.

6.12 Oil Head Motor Assembly

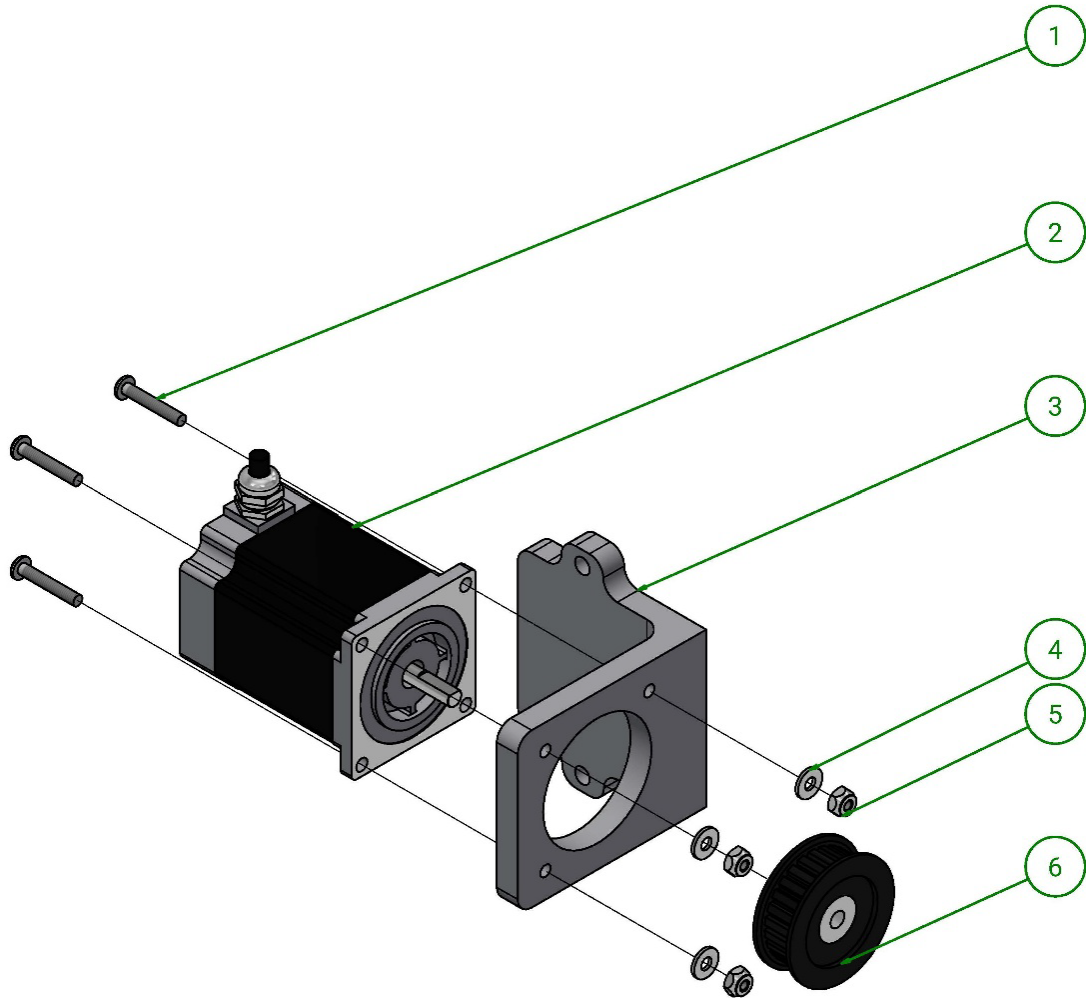

OIL HEAD MOTOR ASSEMBLY

Index Number	Qty.	Part Number	Description	UOM
1	3	153-2089	MS Phillips - 8-32 X 1"	EA.
2	1	164-1263	Stepper Motor	EA.
3	1	166-6041	Head Motor Mount	EA.
4	3	153-2002	Flat Washer - #8	EA.
5	3	153-2019	Locknut (Nylok) - 8-32	EA.
6	1	154-9207	Pulley (24XL037DF 1/4" Bore with set screw	EA.

6.13 Oil Tank Assembly

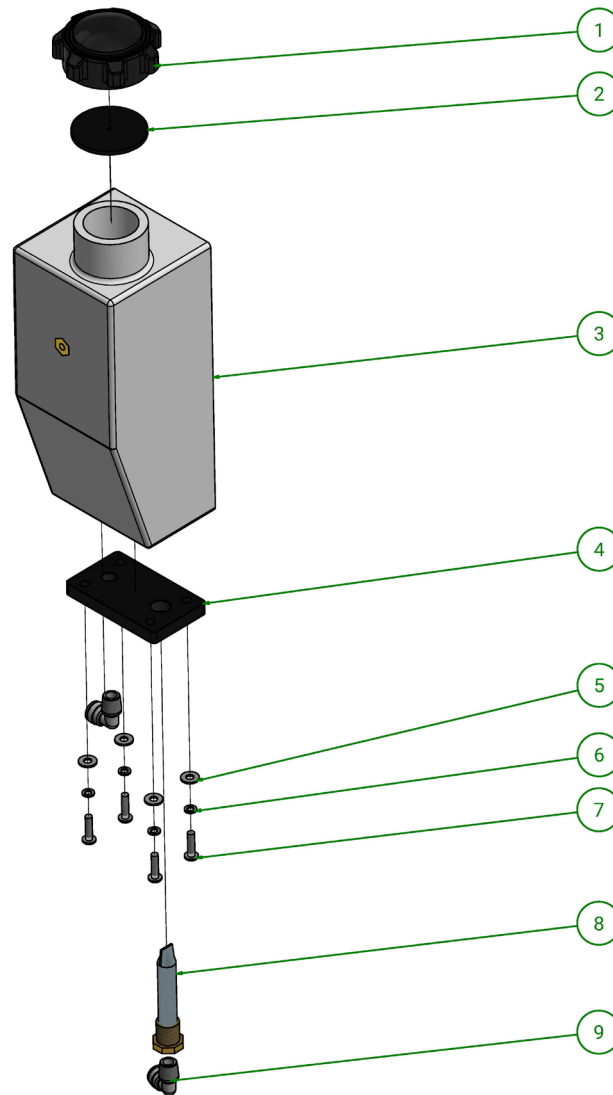

OIL TANK ASSEMBLY				
Item Number	Qty.	Part Number	Description	UOM
1	1	164-6018	Kelch Cap	EA.
2	1	164-0021	Kelch Cap Gasket	EA.
3	1	165-6097M	Oil Tank	EA.
4	1	166-6038	Small Oil Tank Float Plate	EA.
5	4	153-2003	Flat washer - #10	EA.
6	4	153-2013	Lock washer - #10	EA.
7	4	153-2091	MS Phillips - 10-32 X 3/4	EA.
8	1	154-0212	Tank Filter (3" SS) For Oil Tank	EA.
9	3	154-0223	Elbow - 90 Degree - 1/4 NPT x 1/4 Tube	EA.

6.14 Oil Valve Assembly

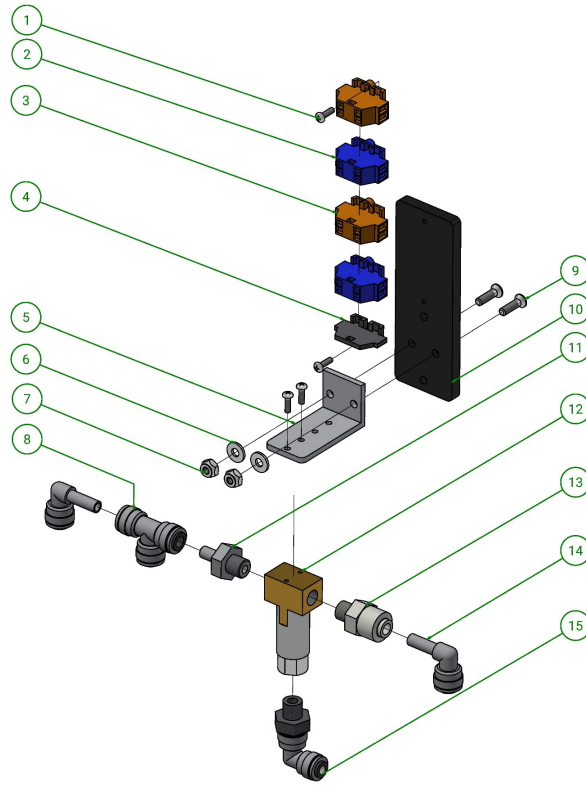

Oil Valve Assembly

Index Number	Qty.	Part Number	Description	UOM
1	4	153-2504	MS Phillips - 4-40 X 3/8	EA.
2	2	154-1245	Terminal Block - Orange 4 Conductor (Wago)	EA.
3	2	154-1244	Terminal Block - Blue 4 Conductor (Wago)	EA.
4	1	154-1247	End Plate for Terminal Block (Wago)	EA.
5	2	153-2086A	MS Phillips - 8-32 X 3/8	EA.
6	2	153-2013	Lock washer - #10	EA.
7	4	153-2002	Flat washer - #8	EA.
8	1	166-6063	Oil Valve Mount Angle	EA.
9	2	153-2019	Locknut - 8-32 (Nylok)	EA.
10	1	153-0815	Union Tee - 1/4 x 1/4 x 1/4 - Quick Disconnect	EA.
11	2	153-2806	Flat head Phillips - 8-32 x 5/8	EA.
12	1	166-6043	Oil Valve Mount	EA.
13	1	166-0013	Stem Adapter - 1/4 X 1/8	EA.
14	1	166-1013	Oil Valve -	EA.
15	1	154-0224	Male Connector - 1/4 Tube x 1/8 NPT	EA.
16	2	154-0222	Elbow - 1/4 Stem x 1/4 Tubing OD	EA.

6.15 Optimizer Bar Assembly

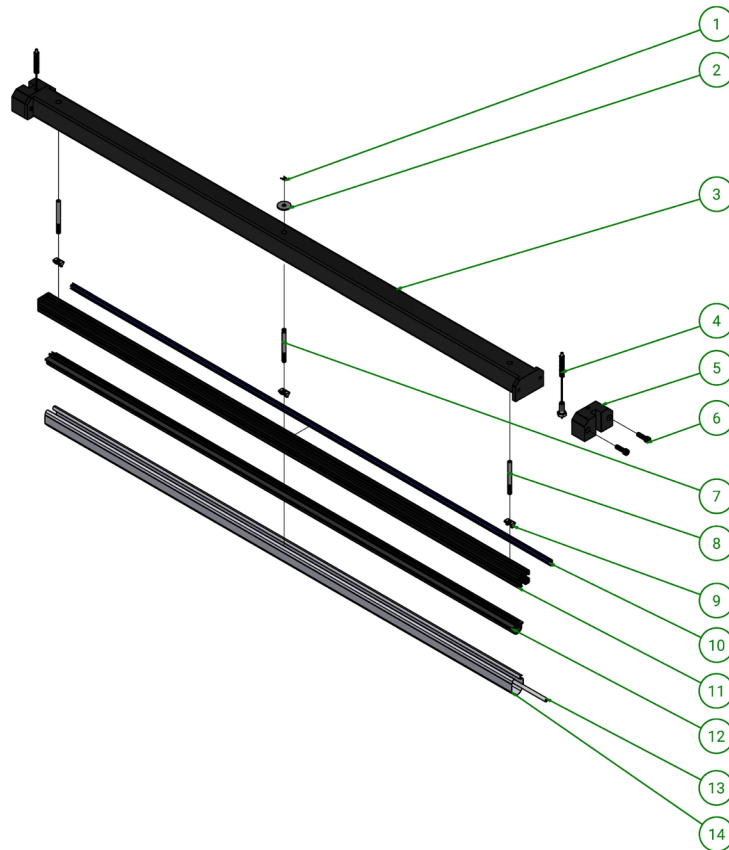

Optimizer Bar Assembly				
Index Number	Qty.	Part Number	Description	UOM
1	1	162-2037	X-Washer	EA.
2	1	162-2013	Washer	EA.
3	1	166-6024-2850	Optimizer Support Bar	EA.
4	2	166-8037	Optimizer Bar Cable	EA.
5	2	166-6020	Optimizer Bar End Block	EA.
6	4	153-2956	Screw – ¼-20 x ¾" Skt Head Cap Screw	EA.
7	1	166-2001M	Optimizer Mount Bar Locating Pin	EA.
8	2	166-2001	¼-20 x 2-1/2 Stud	EA.
9	3	165-2009	Spring Tab Nut	EA.
10	1	166-0017	T-Slot Cover	EA.
11	1	166-6025	Optimizer Mount Bar	EA.
12	1	166-0008	Rubber Seal	EA.
13	1	154-0202A	Pencil Tubing Stock – 1/4OD x 1/8ID	41.5"
14	1	166-0007	Optimizer Pad Cloth	EA.

6.16 Front Guide Wheel Assembly

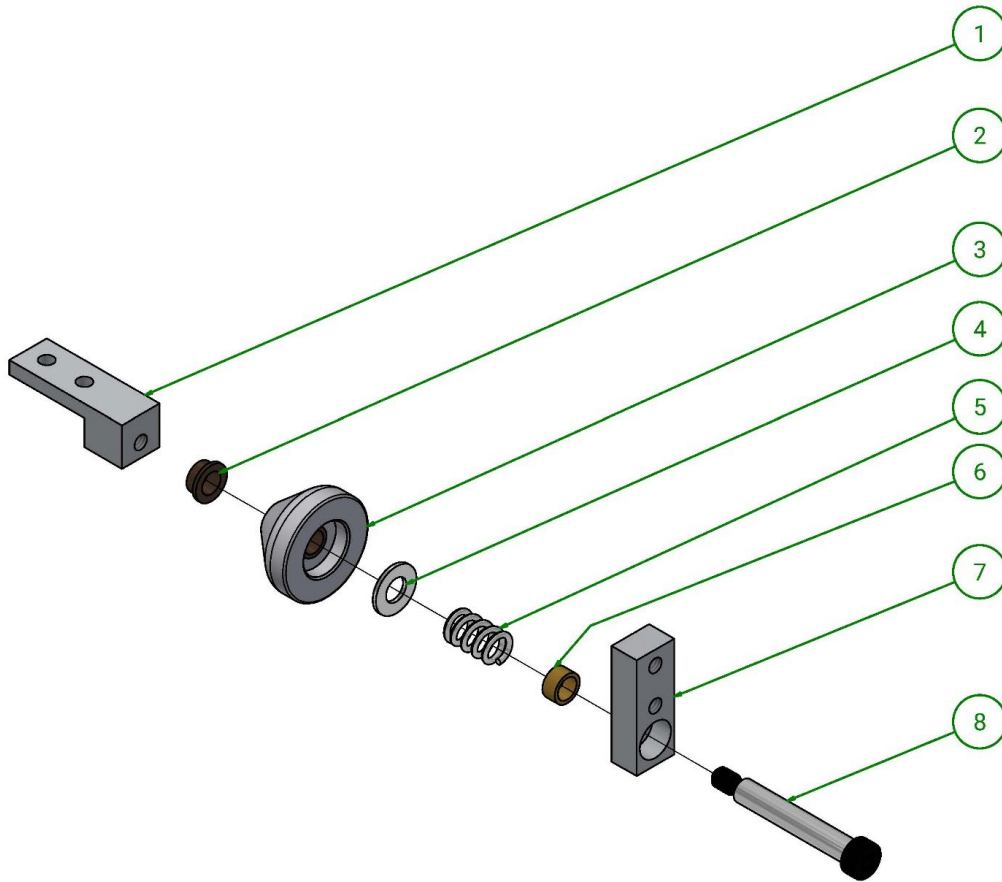

FRONT GUIDE WHEEL ASSEMBLY				
Index Number	Qty.	Part Number	Description	UOM
1	1	154-6870	Front Guide Roller Block	EA.
2	1	153-9803	Flanged Bushing – 3/8" x 1/2" x 1/4"	EA.
3	1	153-8410	Guide Roller Assembly	EA.
4	1	153-2006	Flat washer – 3/8"	EA.
5	1	153-2401	Spring - .54 OD x .75	EA.
6	1	153-9034	Plain Bushing – 3/8 x 1/2 x 1/4"	EA.
7	1	154-6652	Guide Roller Mount Block	EA.
8	1	153-2527	Shoulder Bolt – 3/8 x 2-1/4" – 5/16-18	EA.

6.17 Front Caster Assembly

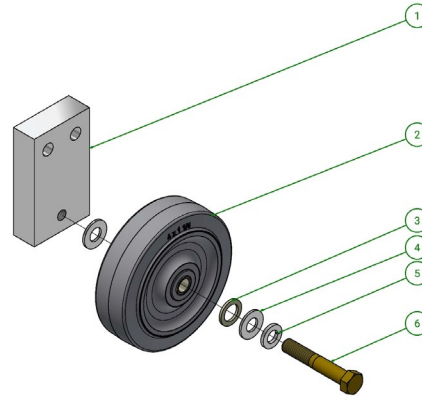

FRONT CASTER ASSEMBLY

Index Number	Qty.	Part Number	Description	UOM
1	1	166-6045	Caster Mount Block – 4"	EA.
2	1	166-0004	Caster Assembly	EA.
3	1	153-2010A	Flat Washer – Nylon ½ x .060	EA.
4	2	153-2006	Flat Washer – 3/8"	EA.
5	1	153-2016	Lock Washer – 3/8"	EA.
6	1	153-2815	HHCS – 3/8-16 x 2-1/4"	EA.

6.18 Side Handle Assembly

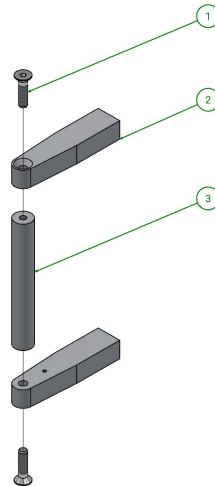

SIDE HANDLE ASSEMBLY

Index Number	Qty.	Part Number	Description	UOM
1	2	153-2503	FHSS – 5/16-18 x 1-1/4"	EA.
2	2	158-6241	Side Handle Mount Bar	EA.
3	1	154-6627	Side Handle Bar	EA.

6.19 Drive Shaft Assembly

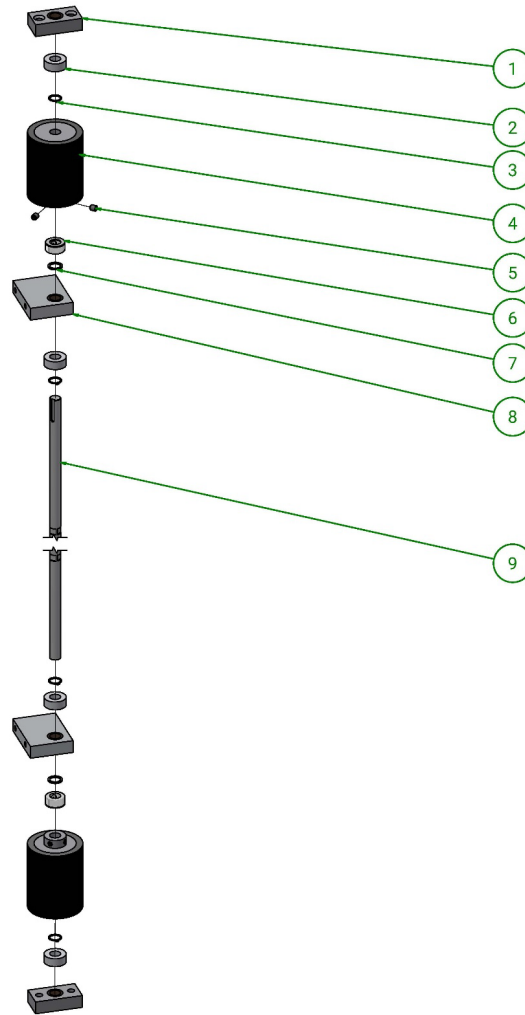

DRIVE SHAFT ASSEMBLY				
Index Number	Qty.	Part Number	Description	UOM
1	2	154-8007	Side Plate Pillow Block Assembly	EA.
2	4	153-0043	Felt Washer – 5/8"	EA.
3	4	153-2036	Snap Ring – 5/8"	EA.
4	2	153-7013	Urethane Drive Wheel Assembly	EA.
5	4	153-2819	Set Screw – 5/16-24 x 3/8"	EA.
6	2	153-2045	Steel Collar – 5/8" x 1-1/8" x 1/2"	EA.
7	2	153-2011	Flat Washer (Nylon) – 5/8" x .060	EA.
8	2	166-6060	Drive Shaft Pillow Block	EA.
9	1	158-6237	Drive Shaft Assembly	EA.

6.20 Touchscreen Assembly

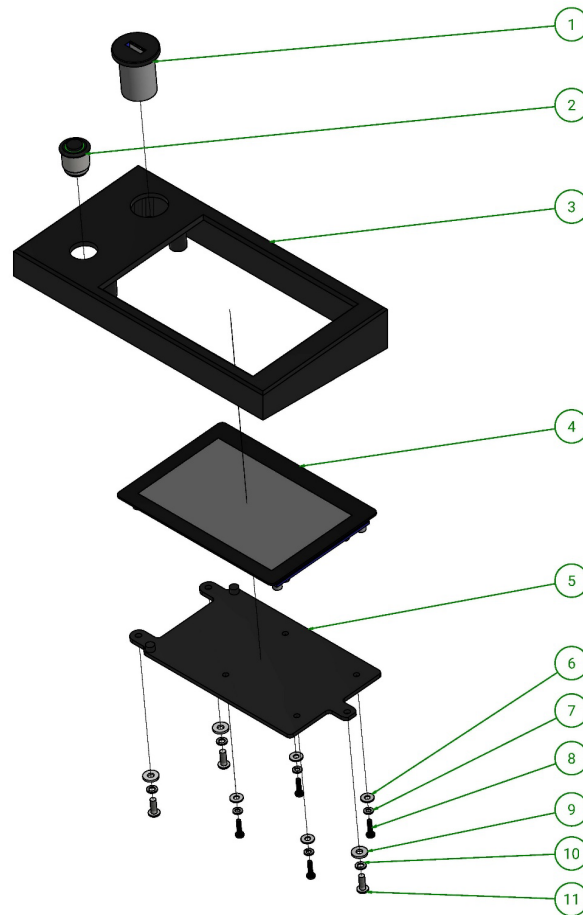

TOUCHSCREEN ASSEMBLY

Index Number	Qty.	Part Number	Description	UOM
1	1	166-1005	Panel Mount USB Jack	EA.
2	1	166-1006	Button Green - 3v	EA.
3	1	166-6031	Screen Mount Assembly	EA.
4	1	166-1001	LCD Screen Assembly	EA.
5	1	166-6033	Screen Backplate	EA.
6	4	165-2004	Washer - #4	EA.
7	4	166-2006	Lock Washer - #4	EA.
8	4	166-2010	Screw - M2.5 x 10	EA.
9	3	153-2001	Flat Washer - #6	EA.
10	3	166-2005	Lock Washer - #6	EA.
11	3	153-2721	MS Phillips - 6-32 x 3/8"	EA.

6.21 Electrical Enclosure Assembly (Fuses)

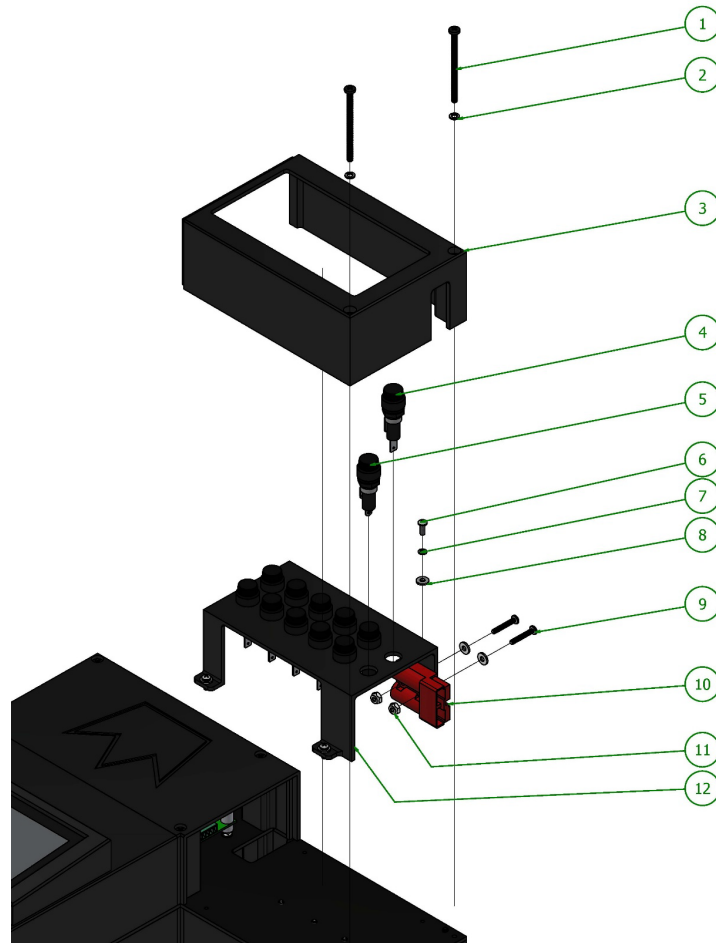

ELECTRICAL ENCLOSURE ASSEMBLY (FUSES)

Index Number	Qty.	Part Number	Description	UOM
1	2	166-2013	MS Phillips (Oxide) - 8-32 x 2.5"	EA.
2	2	166-2012	Lock Washer - #8	EA.
3	1	166-6066	Electrical Enclosure Fuse Cover	EA.
4	11	165-1021	Fuse Holder	EA.
5	1	164-1268	Panel Mount Fuse Holder - 30A	EA.
6	4	153-2721	MS Phillips - 6-32 x 3/8"	EA.
7	4	166-2005	Lock Washer - #6	EA.
8	6	153-2001	Flat Washer - #6	EA.
9	2	153-2083	MS Phillips - 6-32 x 7/8"	EA.
10	1	158-1407	Battery Connector - Red	EA.
11	2	153-2018	Lock Nut - 6-32 (Nylock)	EA.
12	1	166-6070	Electrical Enclosure Fuse Plate	EA.

6.22 Electrical Enclosure Assembly (Contactor & Terminal Block)

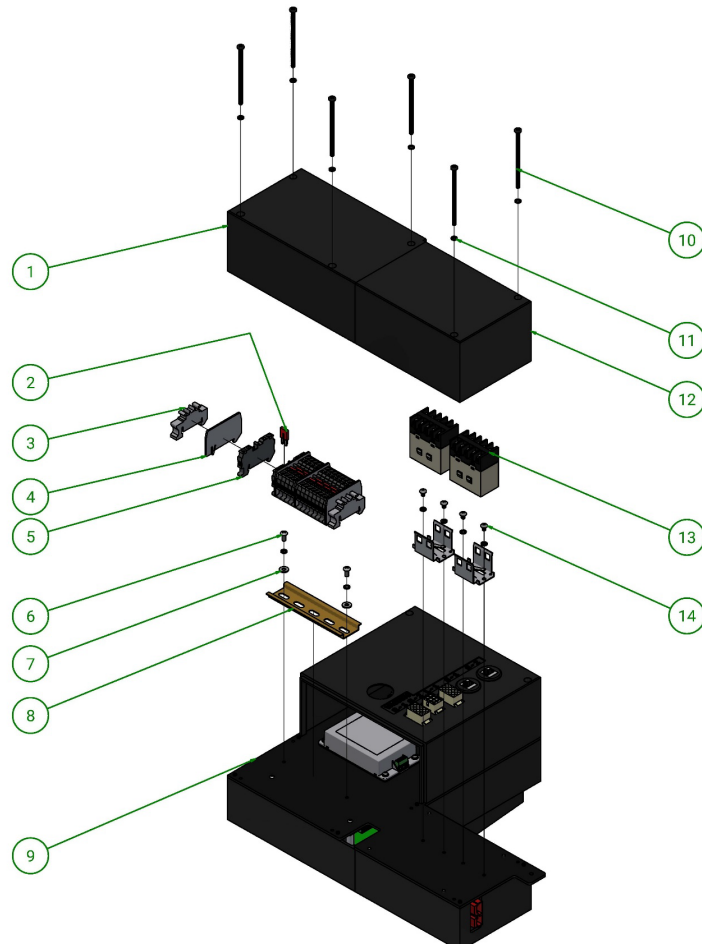

ELECTRICAL ENCLOSURE ASSEMBLY (CONTACTOR & TERMINAL BLOCK)

Index Number	Qty.	Part Number	Description	UOM
1	1	166-6067	Enclosure Bottom Rear	EA.
2	12	158-1417	Terminal Block Jumper	EA.
3	2	158-1430	Terminal Strip End Bracket	EA.
4	4	158-1416	Terminal Block Divider Plate	EA.
5	15	158-1415	Terminal Block - 2 Conductor Grey	EA.
6	2	153-2541	MS Phillips - 8-32 X 1/2"	EA.
7	2	153-2002	Flat Washer - #8	EA.
8	1	153-1809D	Din Rail - 5.75 in.	EA.
9	1	166-6013-2850	Electrical Plate - NEXUS™	EA.
10	6	166-2014	MS Phillips - 8-32 X 3.250 Black Oxide	EA.
11	12	166-2012	Lock Washer - #8	EA.
12	1	166-6069 US	Enclosure Contactor Cover	EA.
13	2	158-1465	Contactor 24DC	EA.
14	4	166-2008	MS Phillips - 8-32 X 1/4"	EA.

6.23 Electrical Enclosure Assembly (Lower Main Section)

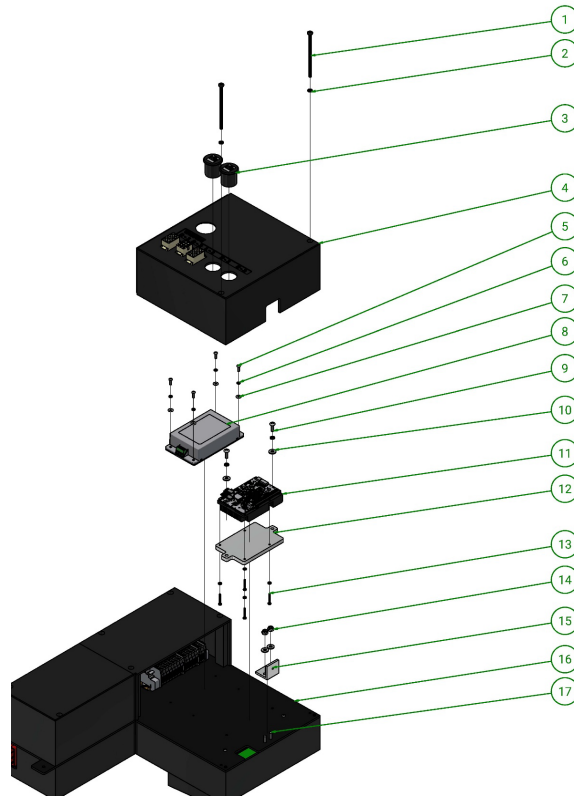

ELECTRICAL ENCLOSURE ASSEMBLY (LOWER MAIN)

Index Number	Qty.	Part Number	Description	UOM
1	2	166-2014	MS Phillips - 8-32 X 3.250 Black Oxide	EA.
2	4	166-2012	Lock Washer - #8	EA.
3	2	166-1004	Panel Mount Network Jack	EA.
4	1	166-6068	Enclosure Bottom Front	EA.
5	4	153-2504	MS Phillips - 4-40 x 3/8"	EA.
6	4	166-2006	Lock Washer - #4	EA.
7	4	165-2004	Flat Washer - #4	EA.
8	1	166-1002	Power Supply - 3.3A	EA.
9	2	153-2541	MS Phillips - 8-32 x 1/2"	EA.
10	4	153-2002	Flat Washer - #8	EA.
11	1	166-1012	Controller Assembly	EA.
12	1	166-6027	Controller Plate	EA.
13	1	166-2009	Screw - M2.5 x 18	EA.
14	2	153-2019	Locknut (Nylock) - 8-32	EA.
15	1	166-6028	Electrical Plate Mount Tab	EA.
16	1	166-6013-2850	Electrical Plate	EA.
17	2	153-2086	MS Phillips - 8-32 x 5/8"	EA.

6.24 Electrical Enclosure Assembly (Upper Main Section)

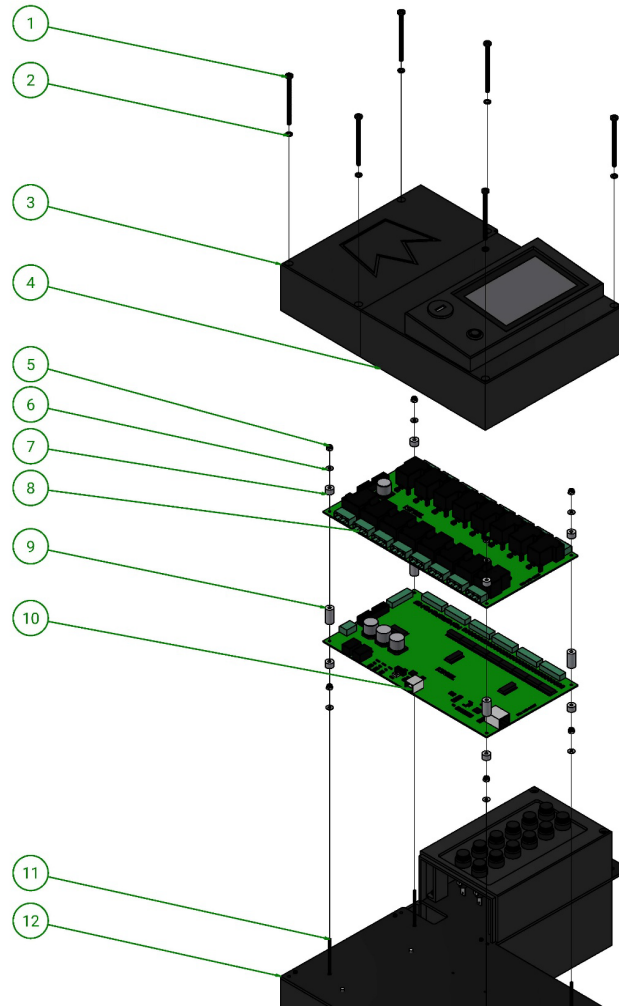

ELECTRICAL ENCLOSURE ASSEMBLY (UPPER MAIN)				
Index Number	Qty.	Part Number	Description	UOM
1	6	166-2013	MS Phillips - 8-32 X 2.5 Black Oxide	EA.
2	6	166-2012	Lock Washer - #8	EA.
3	1	166-6064	Enclosure Top Rear	EA.
4	1	166-6065	Enclosure Top Front	EA.
5	8	153-2231	Locknut - 4-40	EA.
6	8	165-2004	Flat Washer - #4	EA.
7	8	165-2002	Nylon Spacer - #6 x 1/4"	EA.
8	1	165-1028	Relay Board	EA.
9	4	165-2003	Nylon Spacer - #6 x 3/4"	EA.
10	1	165-1027	I/O Control Board	EA.
11	4	165-2005	MS Phillips - 4-40 x 2"	EA.
12	1	166-6013-2850	Electrical Plate	EA.

Section 7 – Electrical Schematics

Electrical schematics are standardized visual representations that illustrate the connections, components, and functionality of an electrical system. This section provides the electrical schematics of the circuits and systems used in the NEXUS. They can be a useful tool for troubleshooting and maintaining your equipment.

7.1 Legend

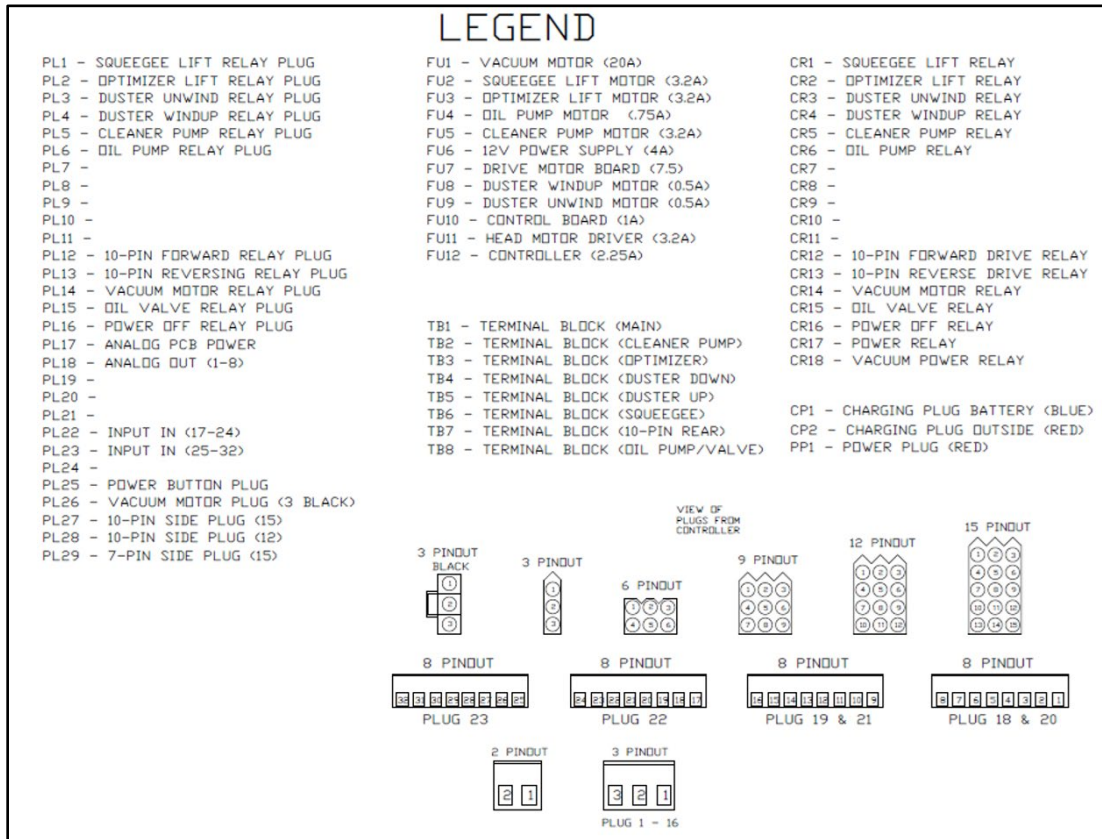

7.2 Analog Wiring

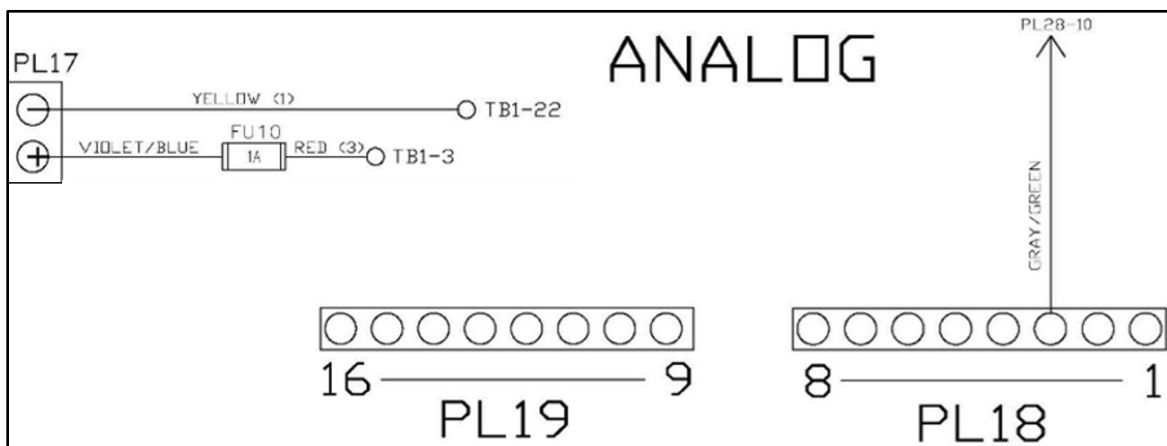

7.3 Cleaner Pump Motor

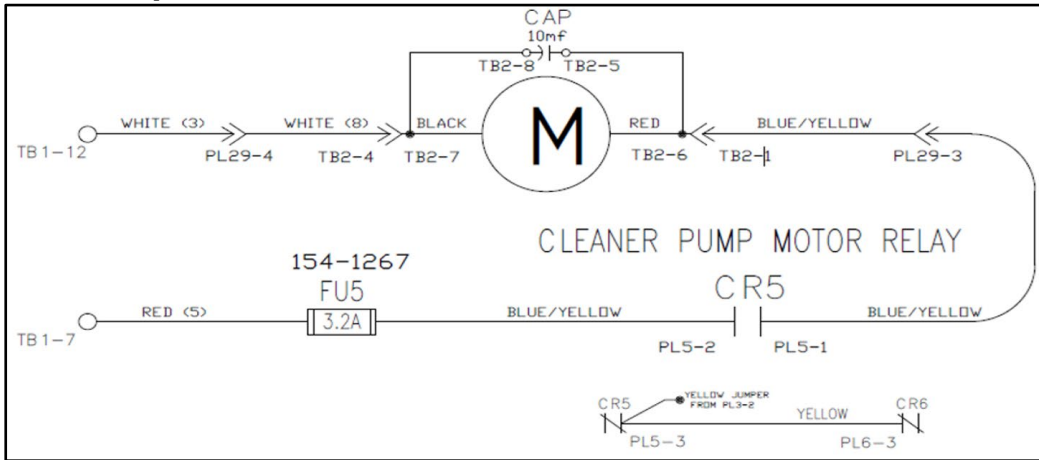

7.4 Duster Unwind Motor & Switch

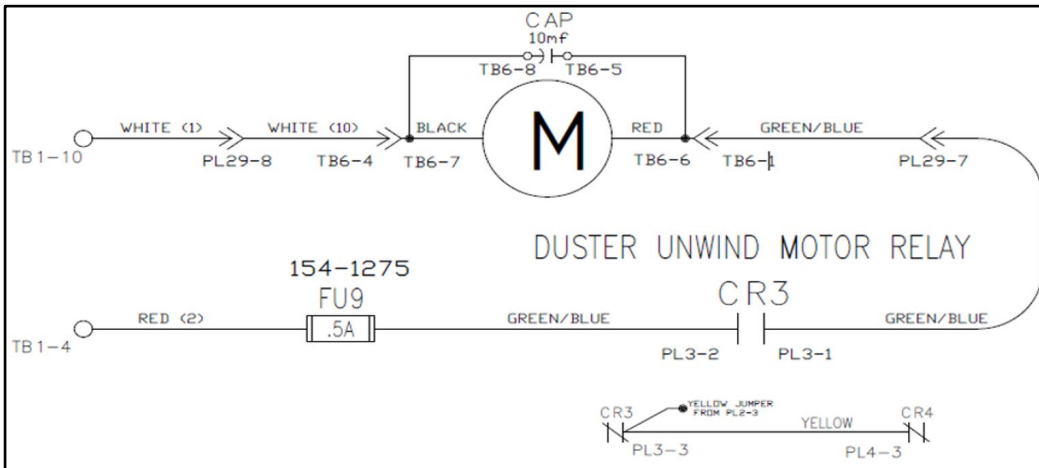

7.5 Duster Windup Motor

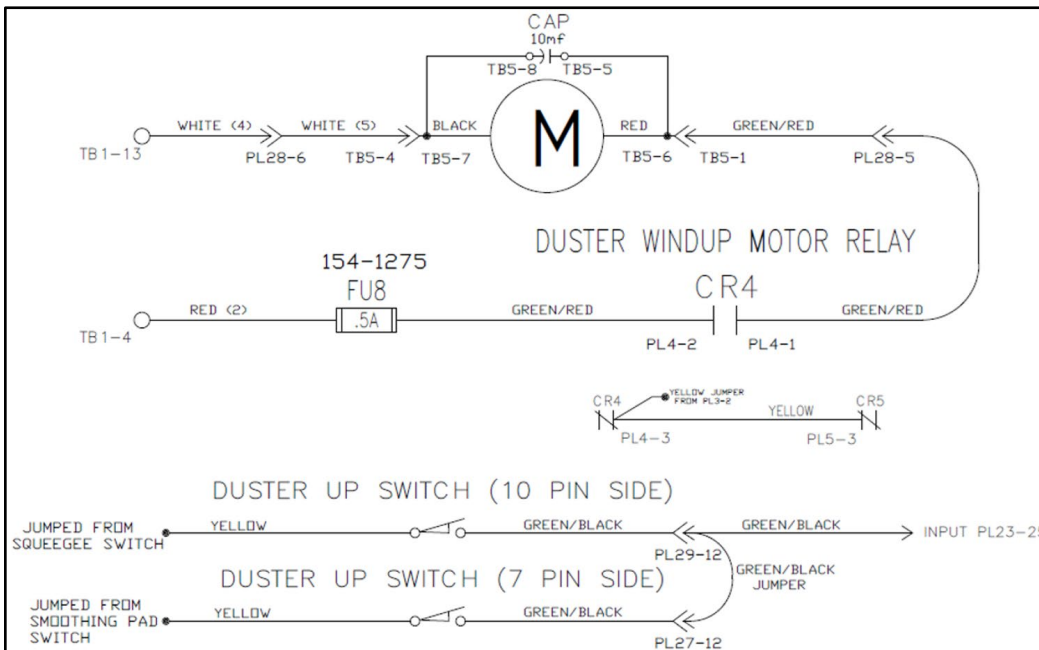

7.6 End of Lane Sensor

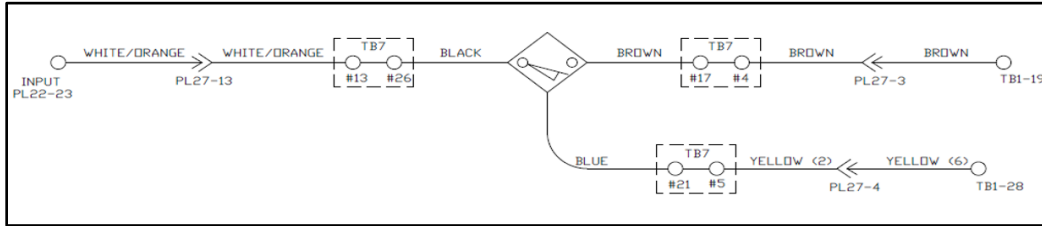

7.7 Inputs

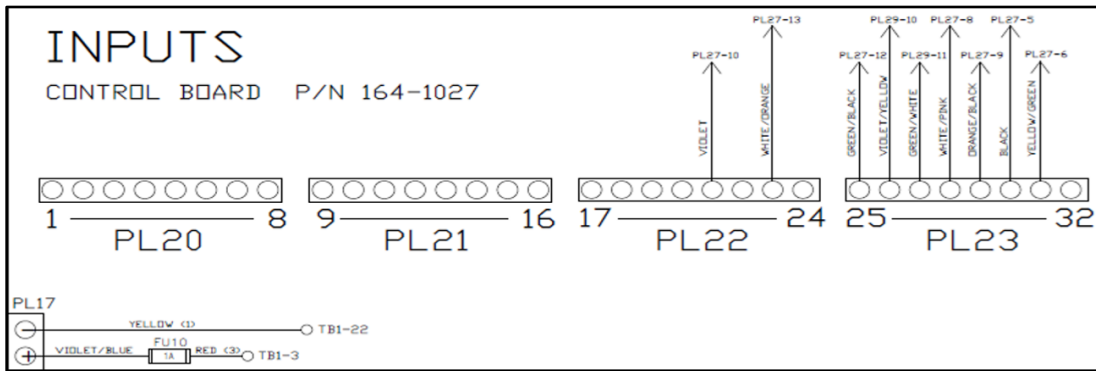

7.8 Lane Distance Sensor Proximity Sensor

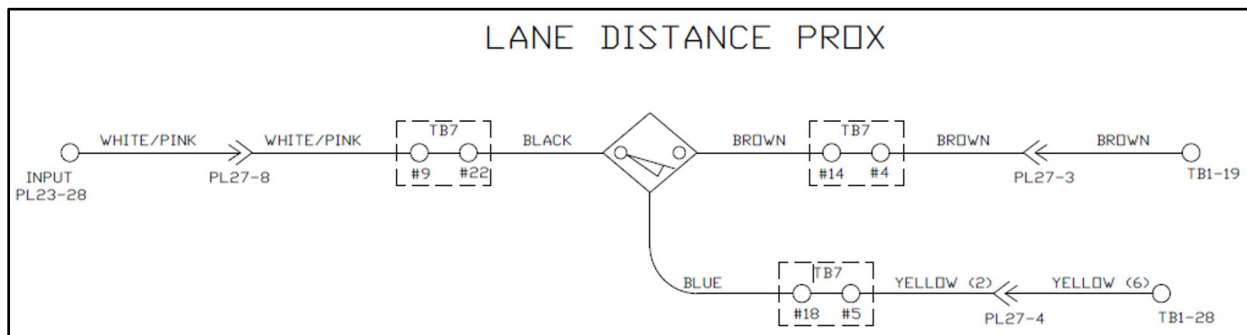

7.9 Handle Start Button

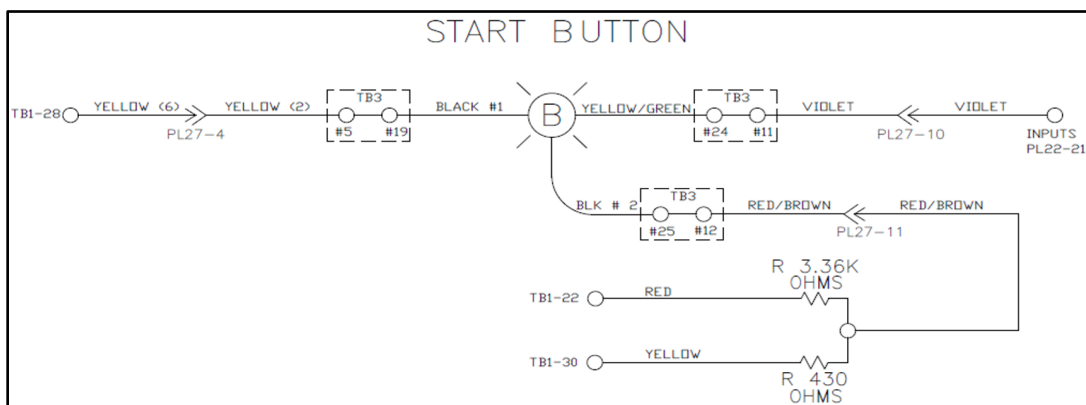

7.12 Oil Pump Motor and Valve

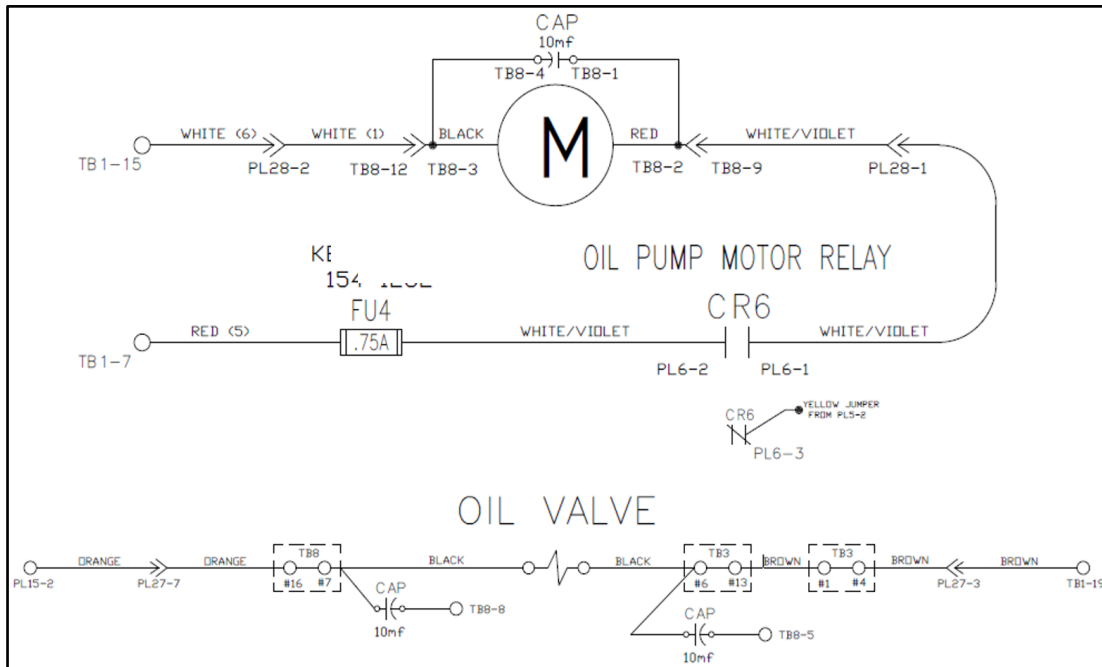

7.13 Optimizer Lift Motor and Switch

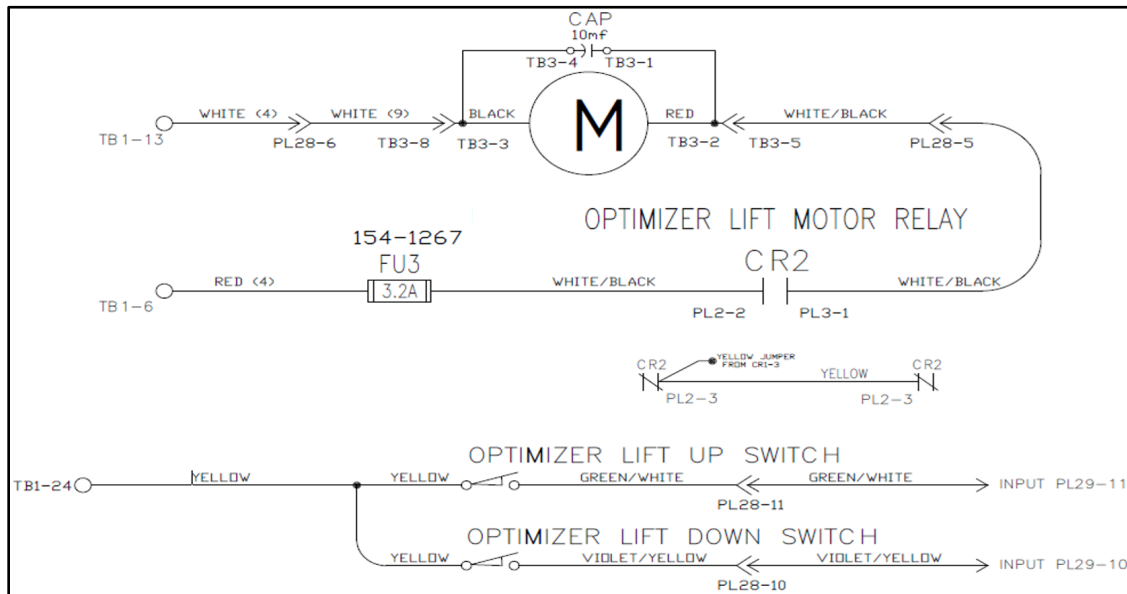

7.14 Outputs

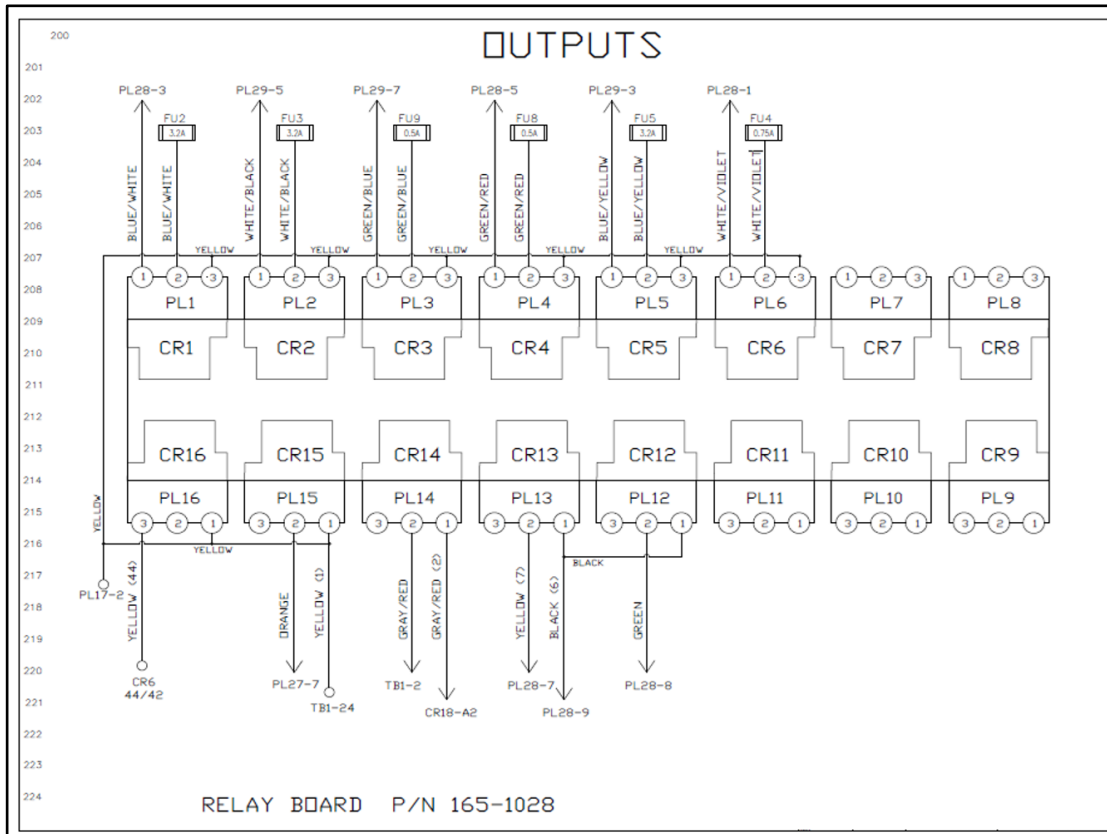

7.15 Power Relay and Power Button

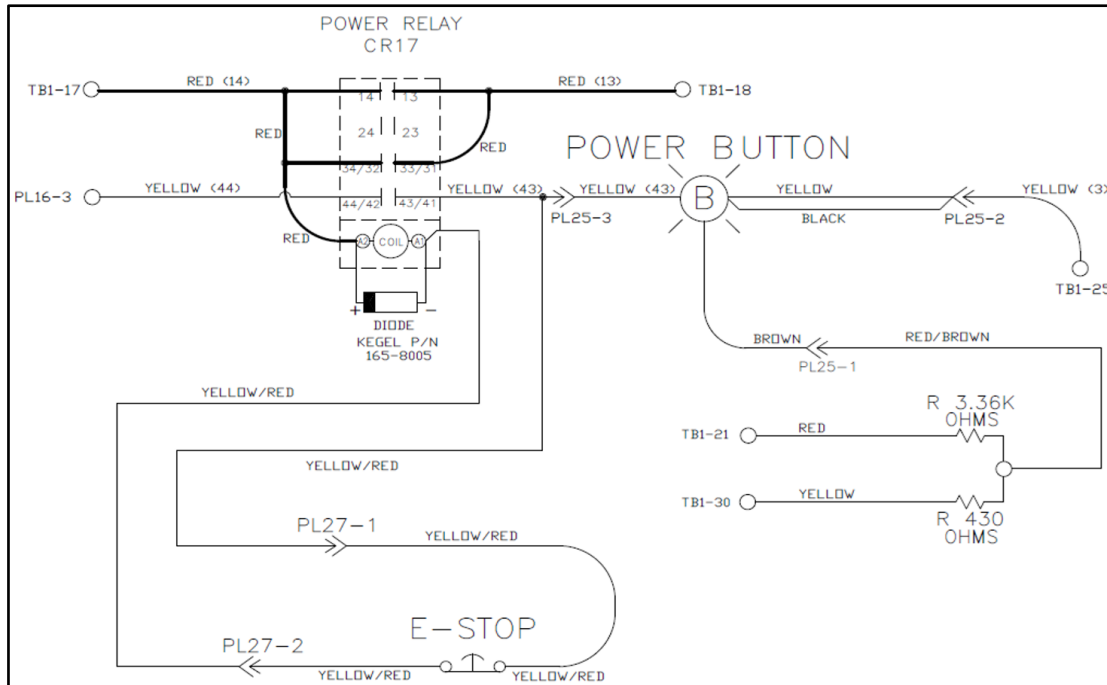

7.16 Squeegee Lift Motor & Switch

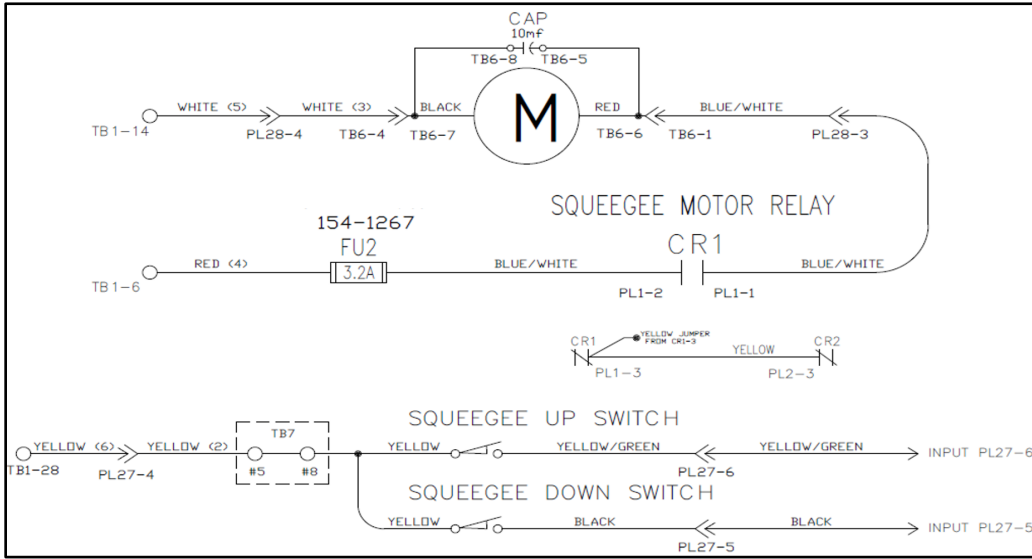

7.17 Terminal Blocks

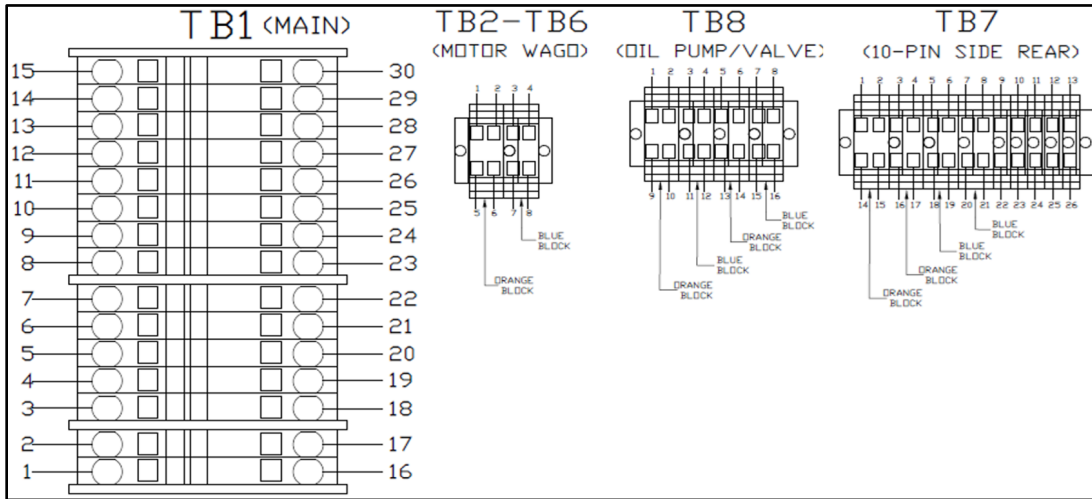

7.18 Vacuum Motor

